

**▲ DANGER**  
HAZARDOUS VOLTAGE FROM ONE OR MORE SOURCES  
Turn off all voltage sources before touching any components. Electrical shock or flash will cause severe injury or death.

421377 - 005 B

QTY.	DESIG.	PART NO.	DESCRIPTION
1	PCB1	600574-004	Assem., Dial Plate, w/Sw. Assm., EN1001, Consisting of: Dial Plate, w/Sw. Assm. & Keylock, EN1001.
1	SW1	600572-002	Assem., Switch, Sequence Control & Display Board
1		600531-001	Assem., Switch, Keylock, Momentary, SPST
1		540245-001	Panel, Display Window, Red Filter, EN1001
1		515104	Panel, Display Window, Red Filter, EN1001
1		565603	Weld Plug, 3/4" Diam., Black
1	PWR.LT.	305001	Lamp, Neon, Red, 230V
1	M.D.LT.	305002	Lamp, Neon, Clear, 230V
1	J2-J3	322326	Assem., Harness, Sec. Ctr'l Bd. to Terminal Strip Bd.
1	J3	322334-006	Assem., Harness, Power, EN1001/GF, "D/T" Cabinet

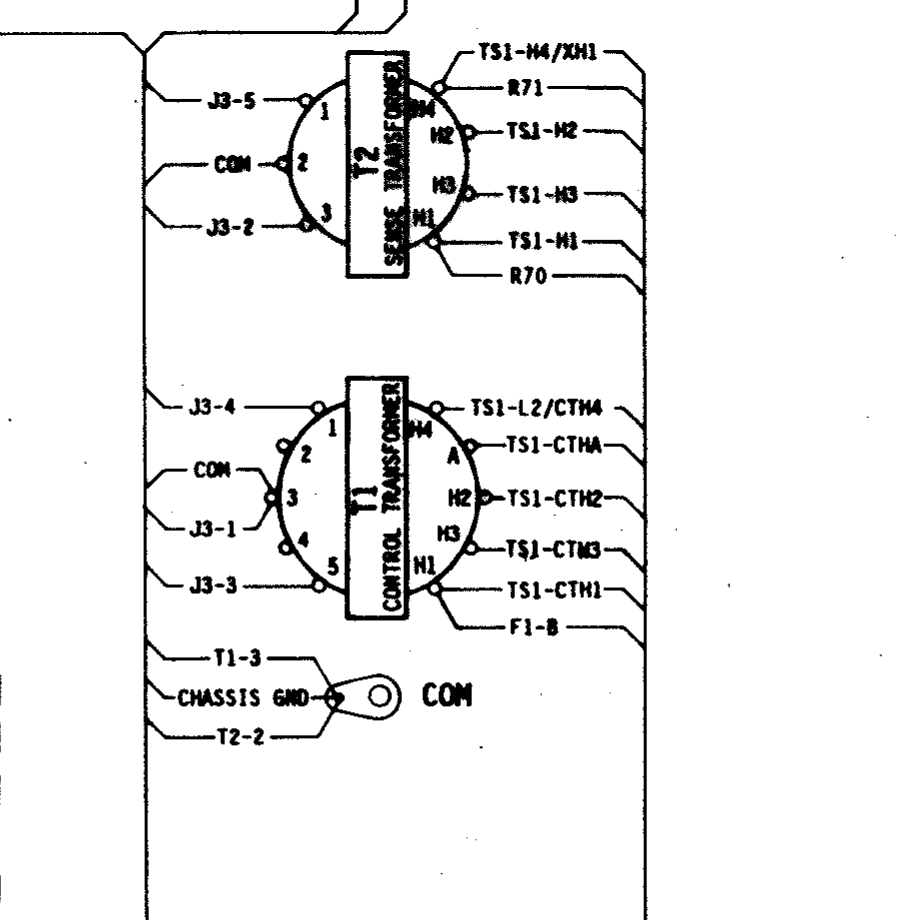
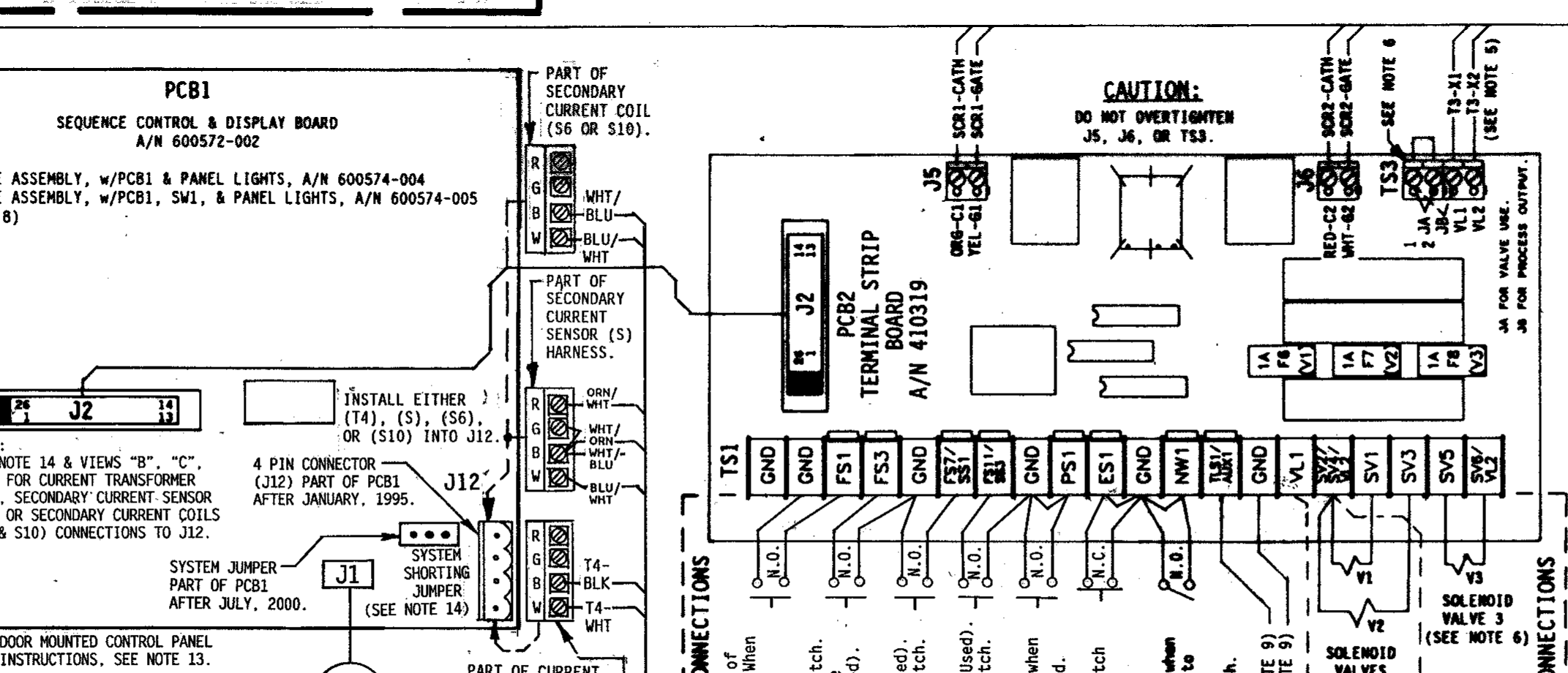
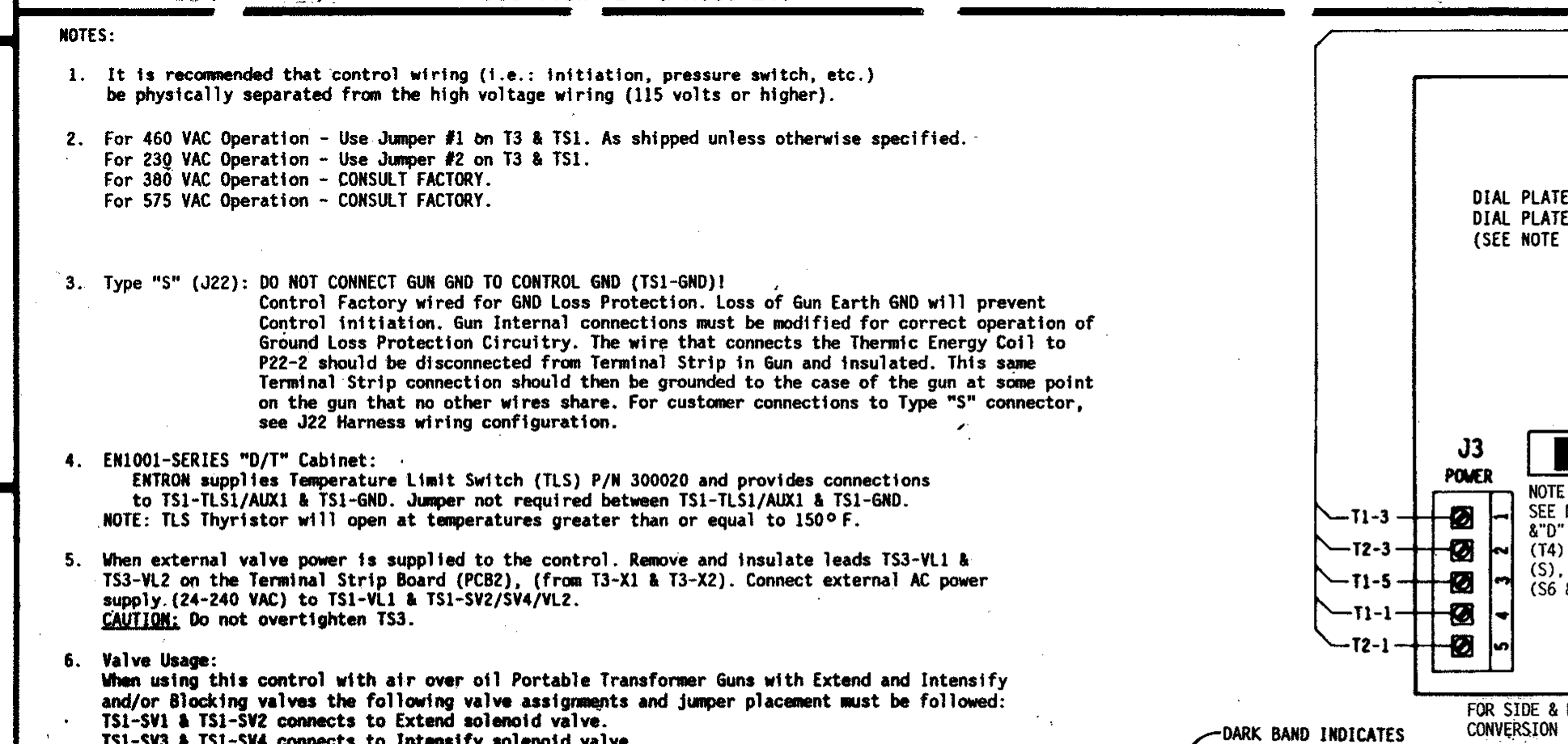

PARTS LIST - CONTACTOR SECTION

QUANTITY	DESIG.	PART NO.	DESCRIPTION
2	TS1, L7	335034	Terminal Strip, 10 Pin, (Part of J3 Harness)
1	TS7	335044	Terminal Strip, 2 Pin, (For T/S/W/S)
+	TS8	335017	Terminal Strip, 2 Pin, (For T/S/W/S)
+	TS9	310001	Transformer, Control, (Part of J3 Harness)
1	T2	310002	Transformer, Sense, (Part of J3 Harness)
1	T3	311002	Transformer, Valve, 150VA
1	T4	311002	Transformer, Valve, 150VA
+	T5	320177	Transformer, Valve, 250V, 575V
+	T6	225016	Resistor, Power, 500 Ohm, 100W
2	R80, R80A	600645	Assem., Resistor, 10,000 Ohm, 1W, (For TS17)
1	R81	210198	Resistor, Metal Oxide, 1 Ohm, 1W, (Part of Current Transformer)
1	R82	600646	Assem., Resistor, 1 Ohm, 1W, (For TS17)
1	F1	308010	Fuseholder, 1 Pole, Mini, 60V
1	F1	307024	Fuse, Control, 1/4A, FWR-1/4 or KLR-1/4
3	F2, 7 (PCB2)	307022	Fuse, 1 Amp, Slow Blow, 2A, (Part of A1001D)
1	(R70, T1)	305024	Assem., Wire, Surge Resistor, 18 Ga., Black
2	(T3)	325149	Assem., Wire, Valve Transformer, 22 Ga., Black
1	600610	600610	Assem., Contactor, Thyristor, Water, 600A, 460/575V
1	346004	346004	Lug, Screw, 5/16 Bolt to 2/0 Wire, 600A Thyristor Contactor, HI
1	346011	346011	Lug, Screw, 1/4 Bolt to 2/0 Wire, 600A Thyristor Contactor, LI
1	341040	341040	Standoff, Insulator, 600/1200A Thyristor Contactor, LI
1	325174	325174	Assem., Wire, Contactor-LI to Lug-LI, 600/1200A Thyristor Contactor
1	600598	600598	Assem., Contactor, Thyristor, Water, 1200A, 460/575V
1	346002	346002	Lug, Screw, 5/16 Bolt to 250 MCM Wire, 1200A Contactor, LI & HI
1	341040	341040	Standoff, Insulator, TSE-HI
1	341040-001	341040-001	Standoff, Modified for Insulator, TSE-HI
4	(TS2)	346002	Lug, Screw, 5/16 Bolt to 250 MCM Wire, 1200A Cont., TSE-HI & TSE-H2
1	(TS2)	341040	Standoff, Insulator, TSE-H2
1	(TS2)	346011	Lug, Screw, 1/4 Bolt to 2/0 Wire, 600A Cont., TSE-HI & TSE-H2
1	TS	309514	Ground Fault Current Transformer
1	CR1	600625	Relay, Residual Current & Ground Detection, supplied w/Manual
1	TS4	300020	Switch, Temperature Limit, (N.C.)
1	SW2	302024	Switch, On/Off, Push Button, Red NCO Contact 22 mm
1	TS5	302025	Switch, On/Off, Push Button, Red NCO Contact 22 mm
1	TS6	346004	Lug, Screw, Chassis GND, 2/0 Wire
1	PCB2	600598	Assem., PCB, Terminal Strip Board, EN1001
1	(PCB2)	510236	Plate, Mounting, Terminal Strip Board
1	329021	329021	Plate, Mounting, 600/1200A Thyristor Contactor
1	324371	324371	Wire, 2/0, 600A Thyristor Contactor, TSE-H2 to C/B-L2, 30" Long
1	324372	324372	Wire, 2/0, 600A Thyristor Contactor, TSE-H1 to Cont-H1, 20" Long
1	324365	324365	Wire, 2/0, 600A Thyristor Contactor, C/B-L1 to Cont-L1, 18" Long
1	324373	324373	Wire, 250 MCM, 1200A Thyristor Contactor, TSE-H2 to C/B-L2, 25" Lg.
1	324374	324374	Wire, 250 MCM, 1200A Thyristor Contactor, TSE-H1 to Cont-H1, 18" Lg.
1	324368	324368	Wire, 250 MCM, 1200A Thyristor Contactor, C/B-L1 to Cont-L1, 14" Lg.
1	600599	600599	Assem., Secondary Current Sensor (S)
1	J2-J3	322327	Assem., Harness, Secondary Current Sensor
1	T4	SEE CHART	Assem., Transformer, Current, 500:5, PS
1	SEE CHART	600647	Assem., Transformer, Current, 1000:5, P10
1	600648	600648	Assem., Transformer, Current, 2500:5, P10
1	S6	600668	Secondary Current Coil, S6, 50 Ohm, 100V
1	S10	600668	Secondary Current Coil, S10, 50 Ohm, 100V
36"	J1E-J1E	900045	Hose, 3/8" I.D.
4		560610	Hose Clamp, 3/8" Hose
2		600179	Assem., Water Fitting, 3/8" Hose
1	WFS	600297	Assem., Meter Fitting, 3/8" Hose
1		550014	Vault Closing Door Mechanism, "D/T" Cabinet
1		510247-002	Cabinet, Control, Style "D/T", w/CS, Modified for GF
1		510248	Door, Cabinet, Control, Style "D/T"
1	C/B	346004	Circuit Breaker, Pole, Amp, V, w/110 VAC Shunt Trip
1		700120	Manual, EN1001
1		421271	Logic Diagram, EN1001 Control
1		421377-005	Wiring Diagram, EN1001-600/1200/GF, "D/T" Cabinet, & 120 VAC VALVES

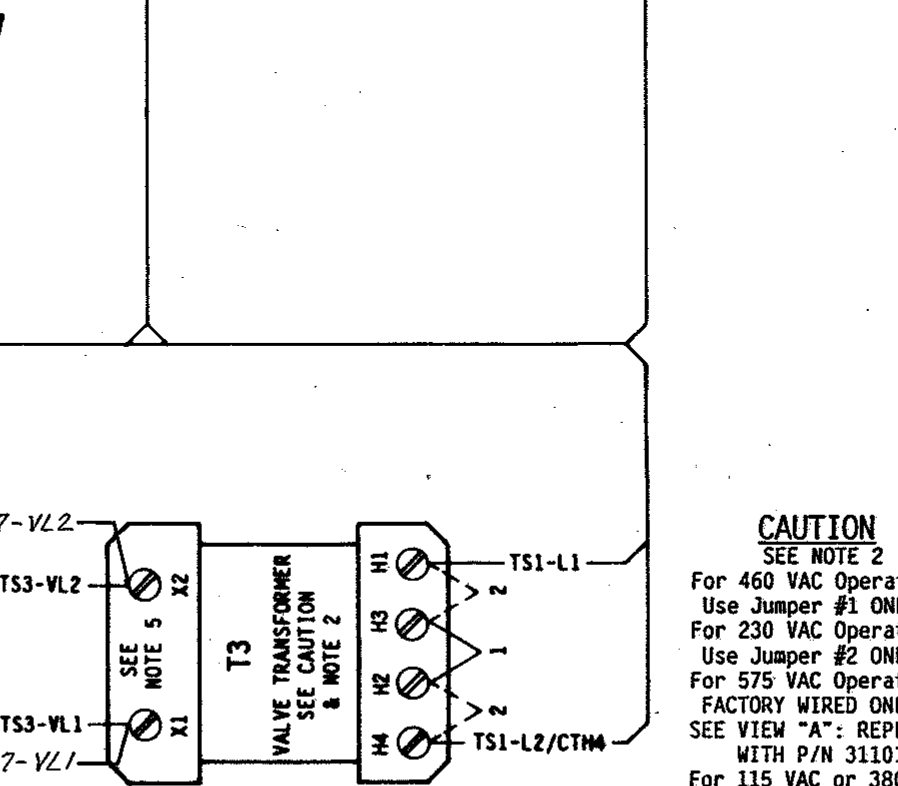
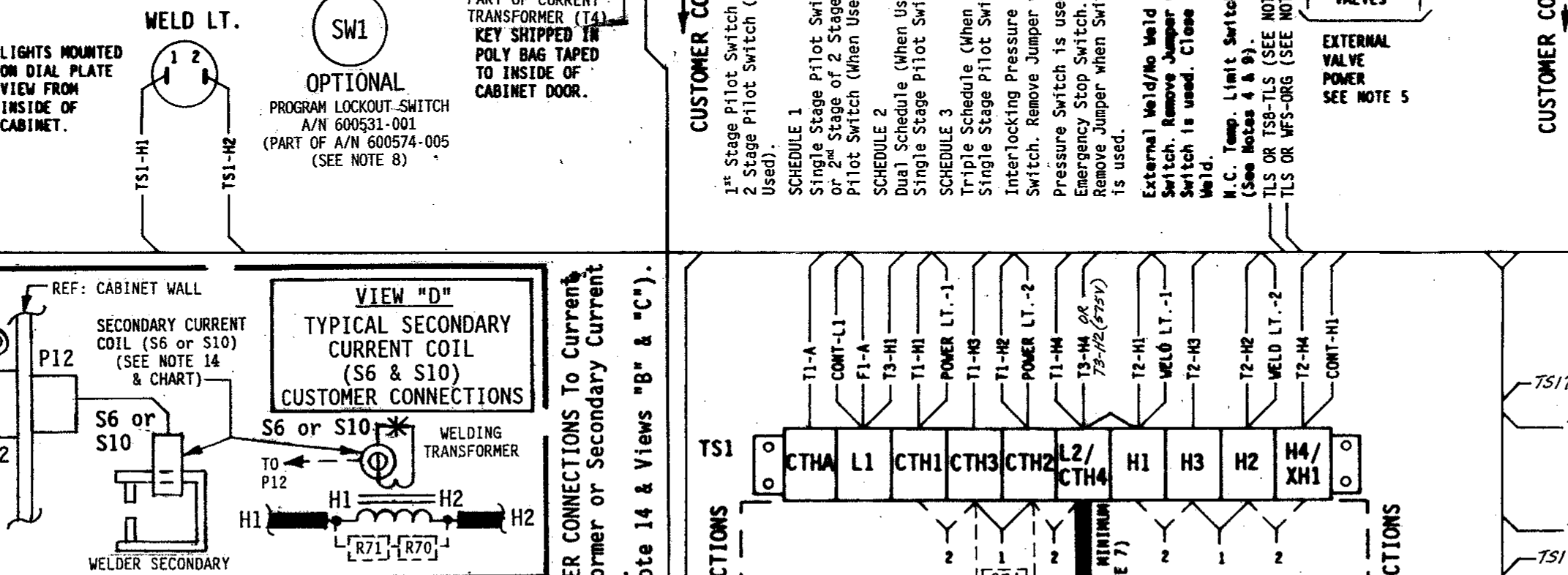
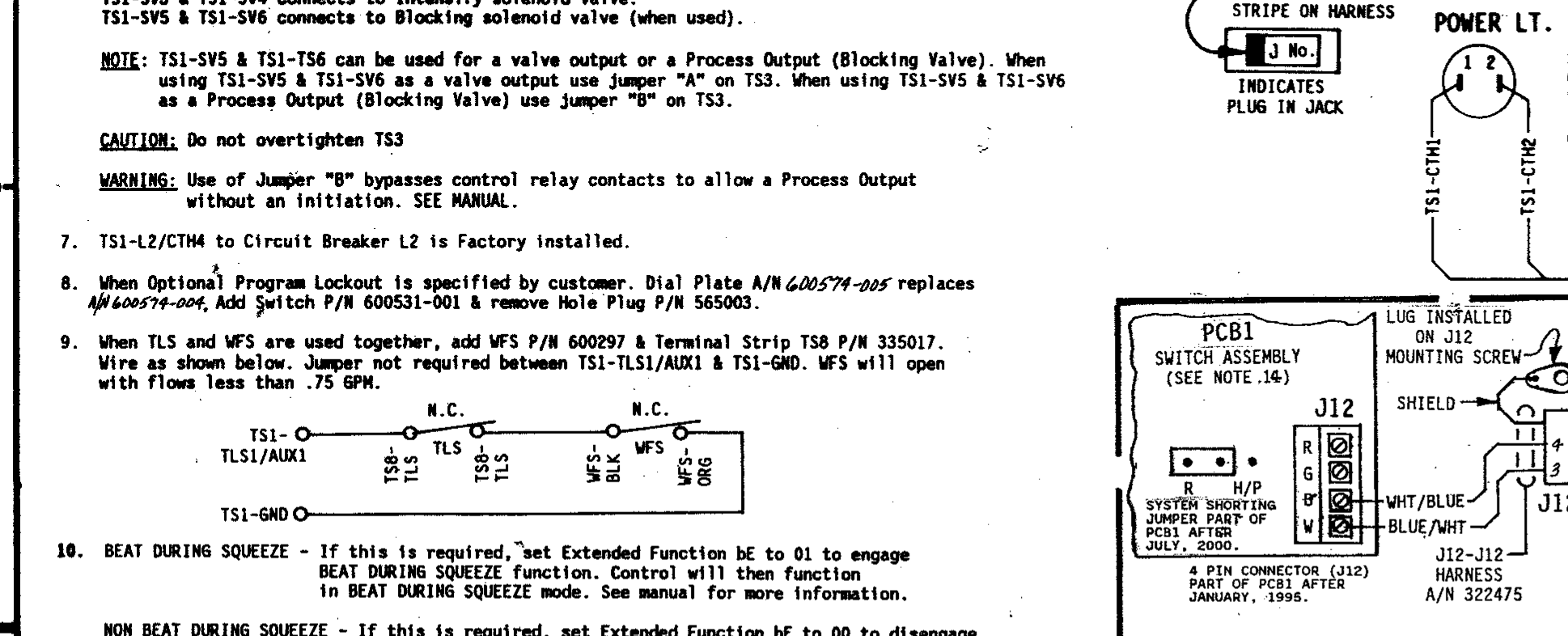

CAUTION - CONTROL WIRING FOR 460 VAC OPERATION - UNLESS OTHERWISE SPECIFIED.

NOTE: PRIOR TO 10-1-00, FUSE F1 WAS P/N 307018, 6/10A, TYPE BBS 6/10.

NOTE: FUSE F1 WAS P/N 307018, 6/10A, TYPE BBS 6/10.

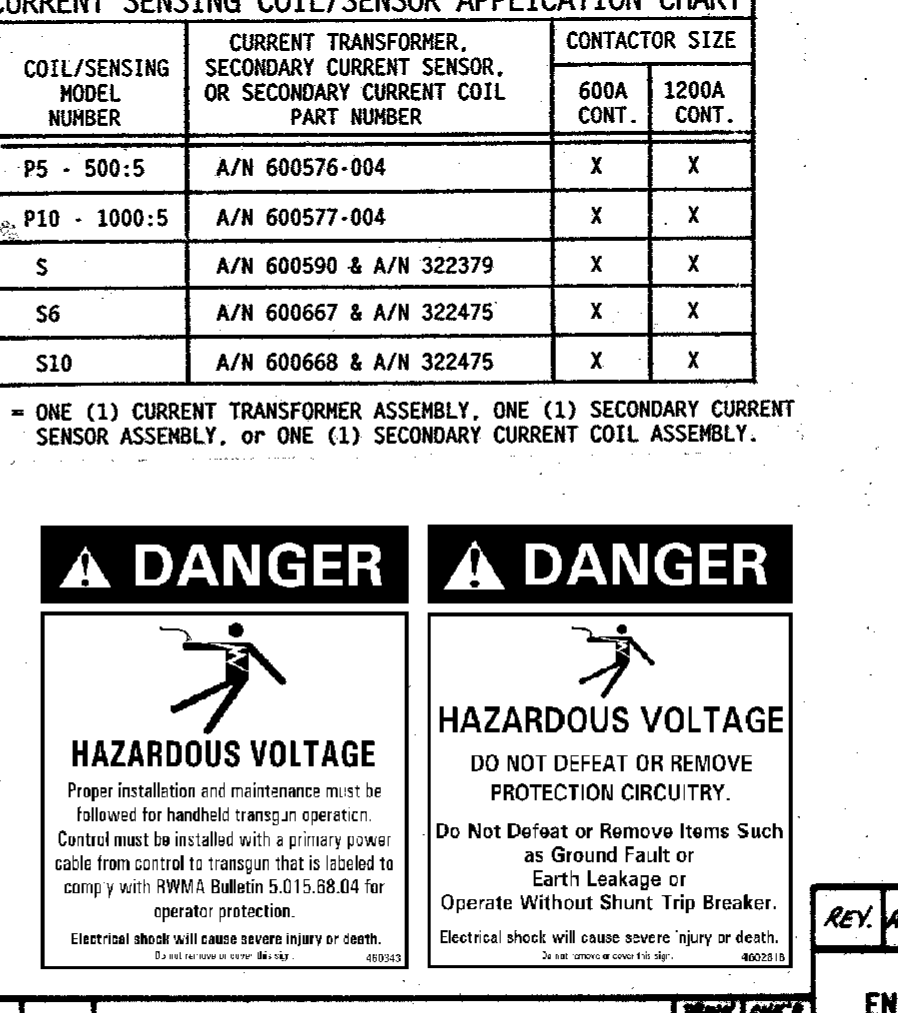
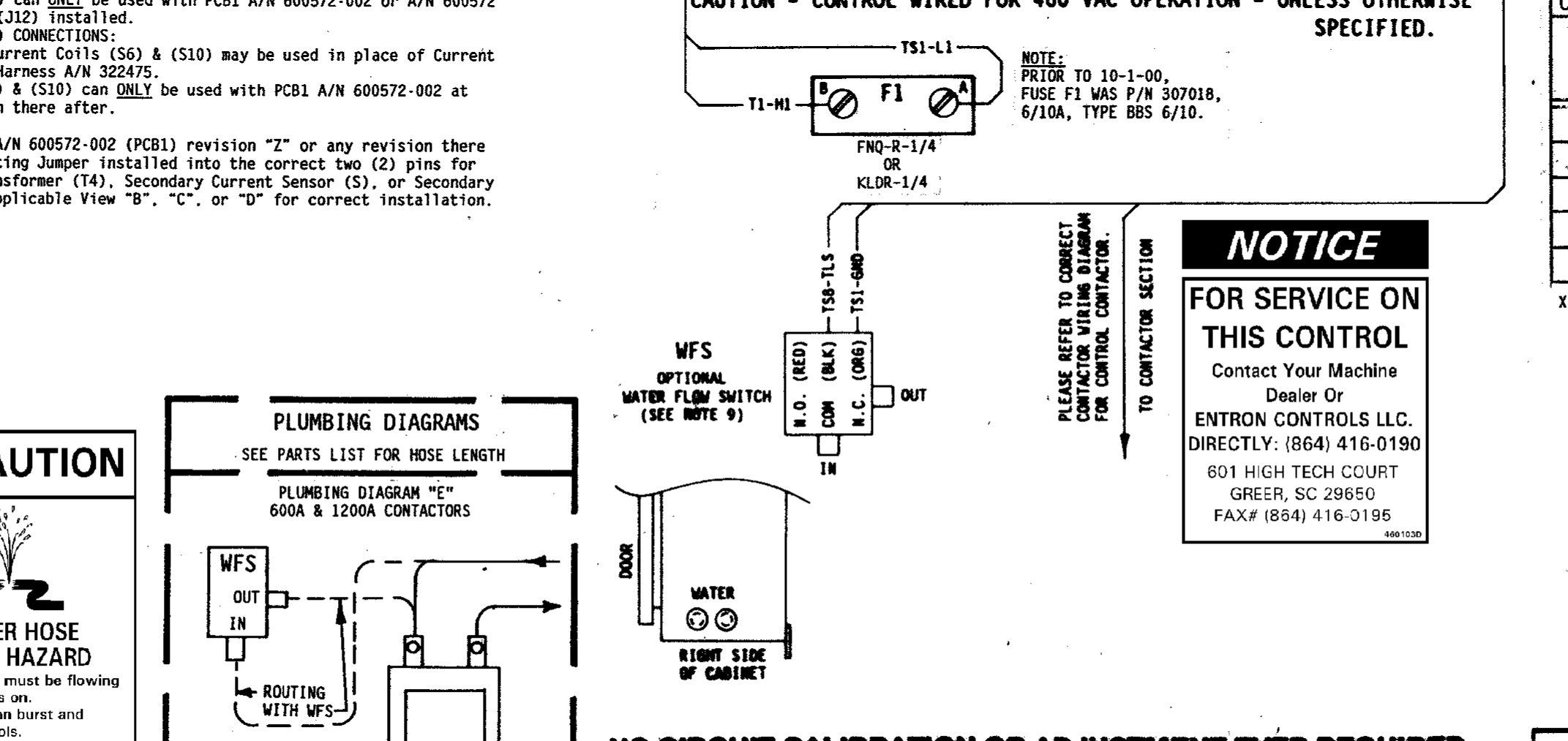
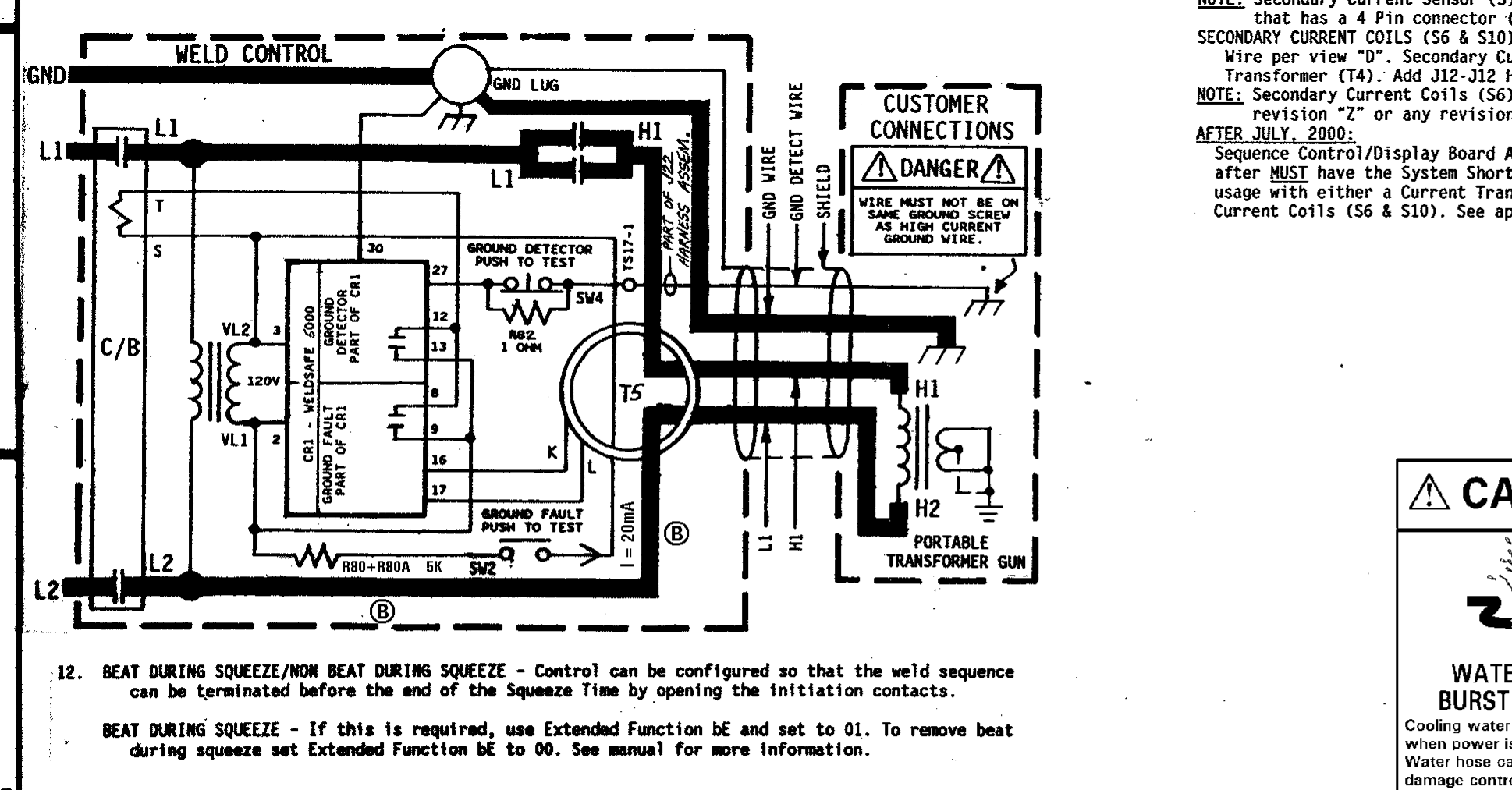
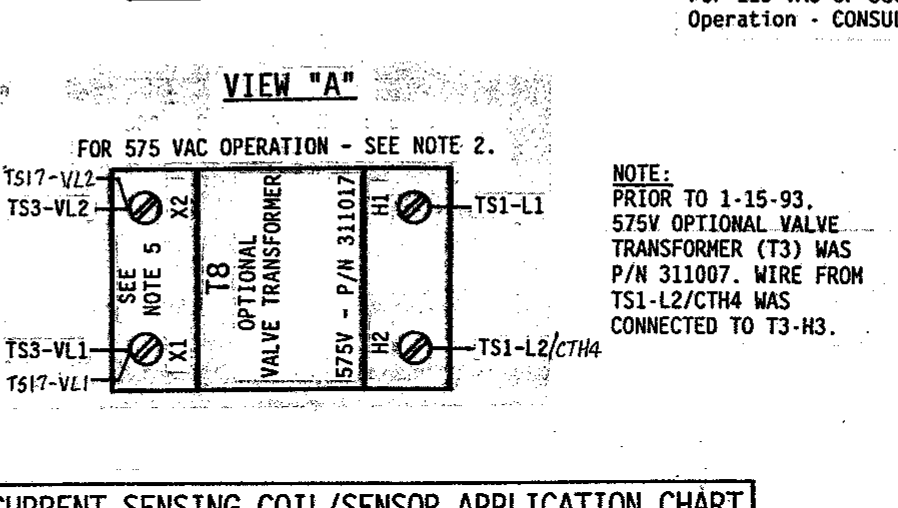
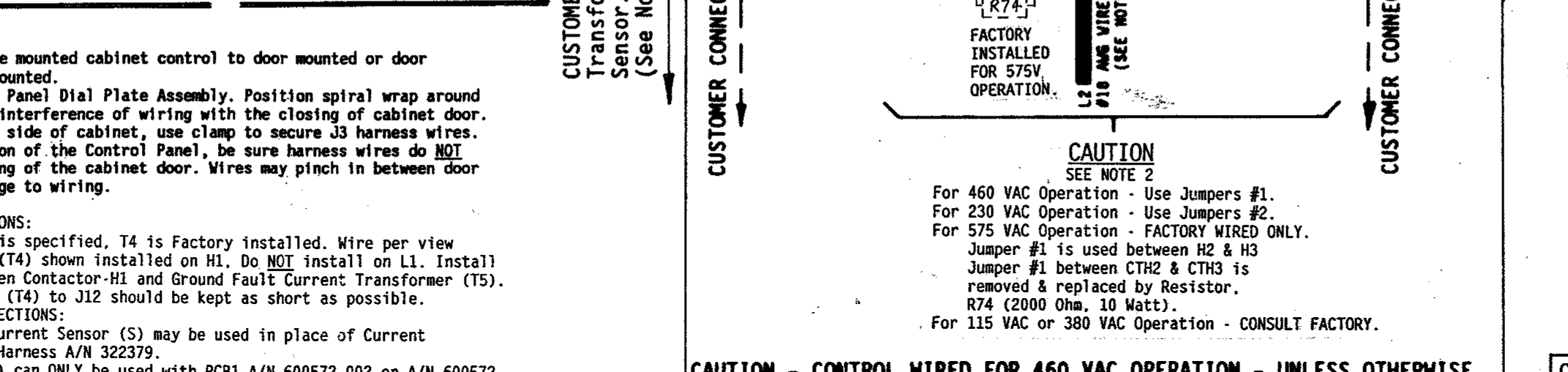
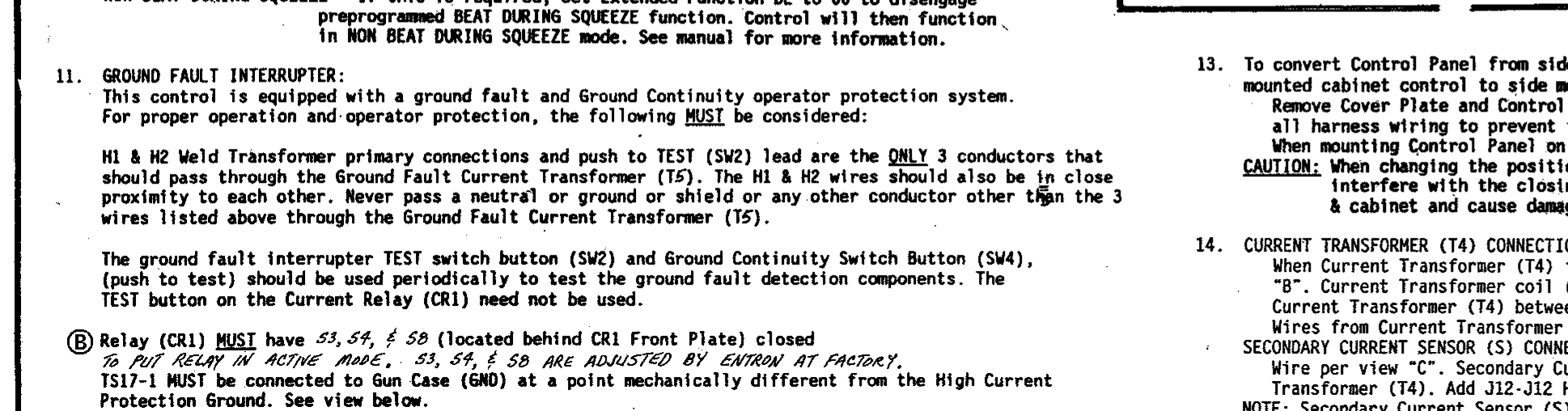

**NOTICE**

This weld control complies with the RWMA Bulletin S.015.08.04 for use with a hand-held transducer.

Proper installation and maintenance must be followed for hand-held transducer operation.

See instructions.

**▲ DANGER**  
HAZARDOUS VOLTAGE  
Electrical shock will cause severe injury or death.

**▲ DANGER**  
SHOCK HAZARD  
TEST OPERATOR PROTECTION BEFORE USE.  
ELECTRICAL SHOCK OR FLASH WILL CAUSE SEVERE INJURY OR DEATH.

**ENTRON CONTROLS INC.**

SCALE DATE	DRAWN BY	CHK'D BY	APPROVED BY
8-28	DEC	DEC	DEC

WIRING DIAGRAM, EN1001-1200/GF, "D/T" CABINET WITH CIRCUIT BREAKER & 120 VAC VALVES

421377-005 B