

PARTS LIST - CONTROL SECTION 421387-008 C. Table with columns: QTY., DESIG., PART NO., DESCRIPTION. Lists components like dial plate, switches, relays, and lamps.

- NOTES: 1. It is recommended that control wiring... 2. For 460 VAC Operation - Use Jumper #1... 3. NIMAK Type (J22): DO NOT CONNECT GUN GND TO CONTROL GND... 4. NK1000-SERIES, "D/T" CABINET: ENTRON supplies Temperature Limit Switch (TLS) P/N 300020...

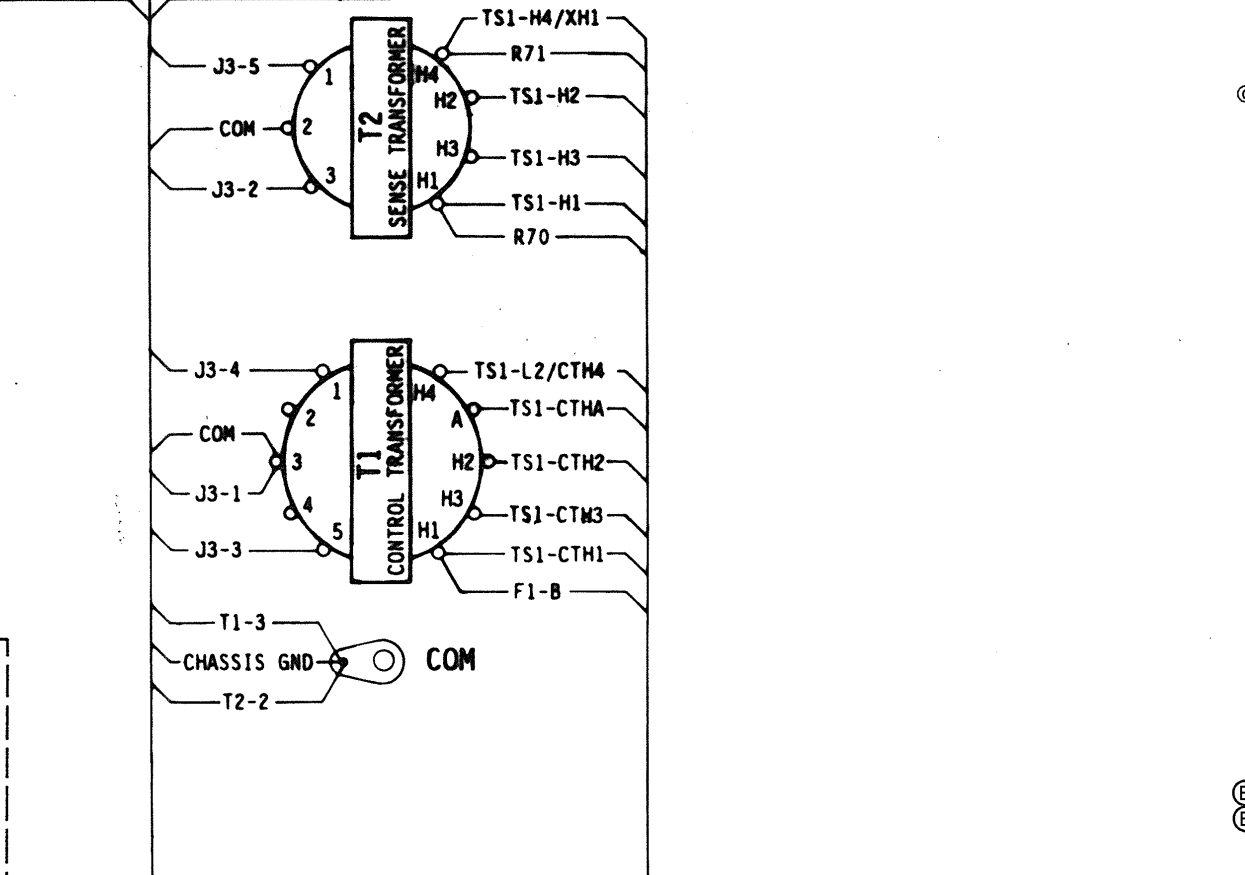

PARTS LIST - CONTACTOR SECTION. Table with columns: QTY., DESIG., PART NO., DESCRIPTION. Lists components like terminal strips, transformers, resistors, and valves.

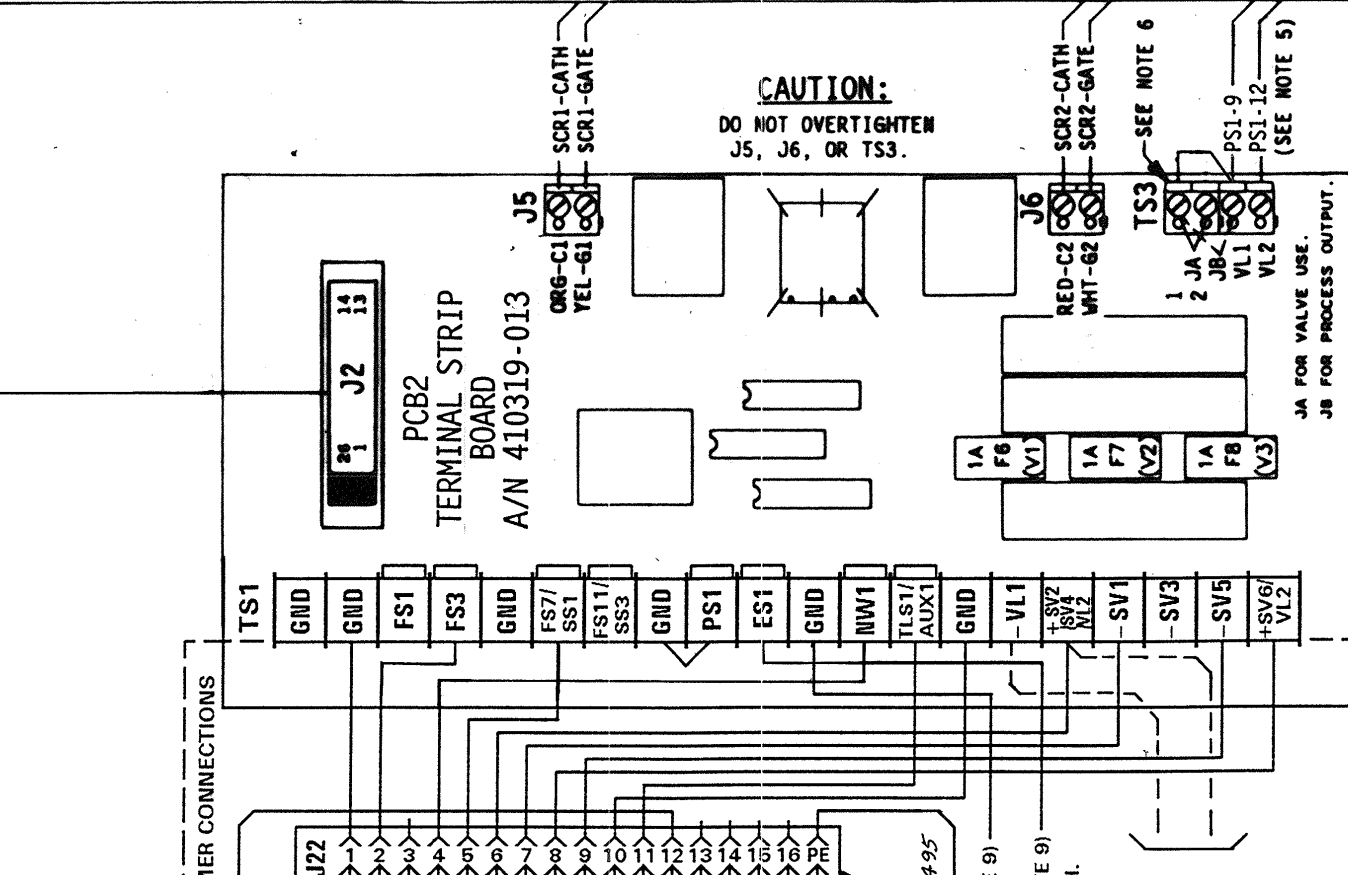
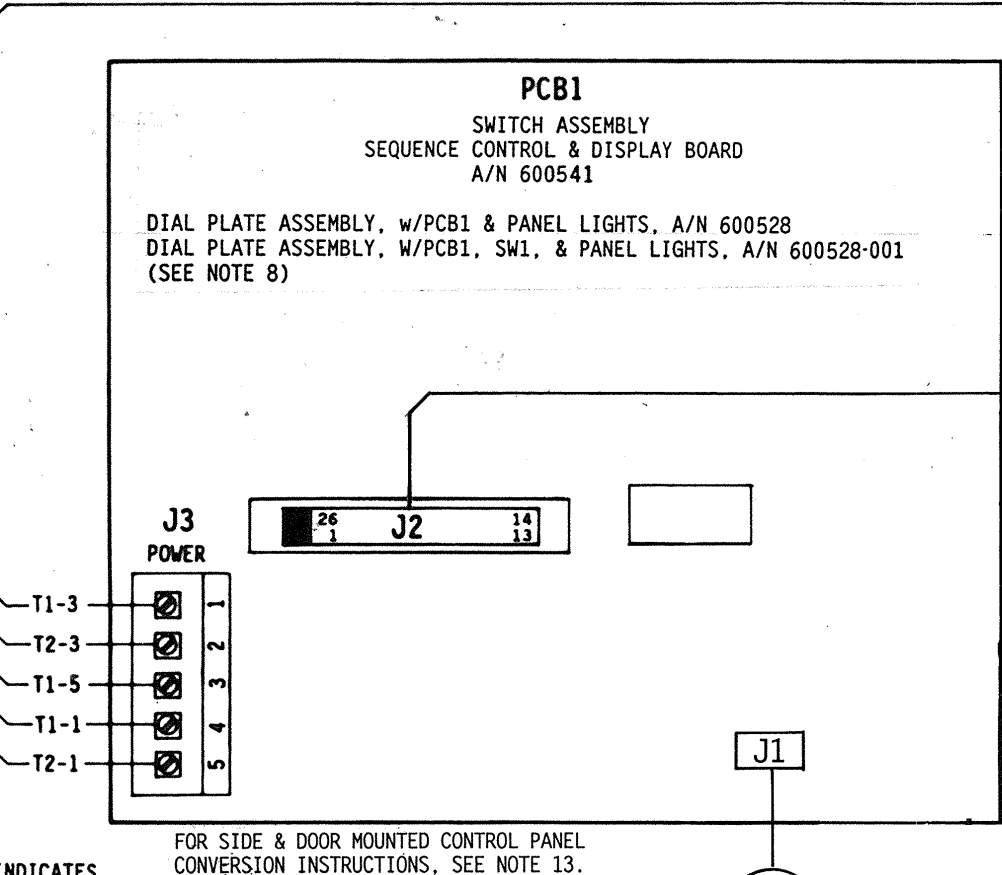
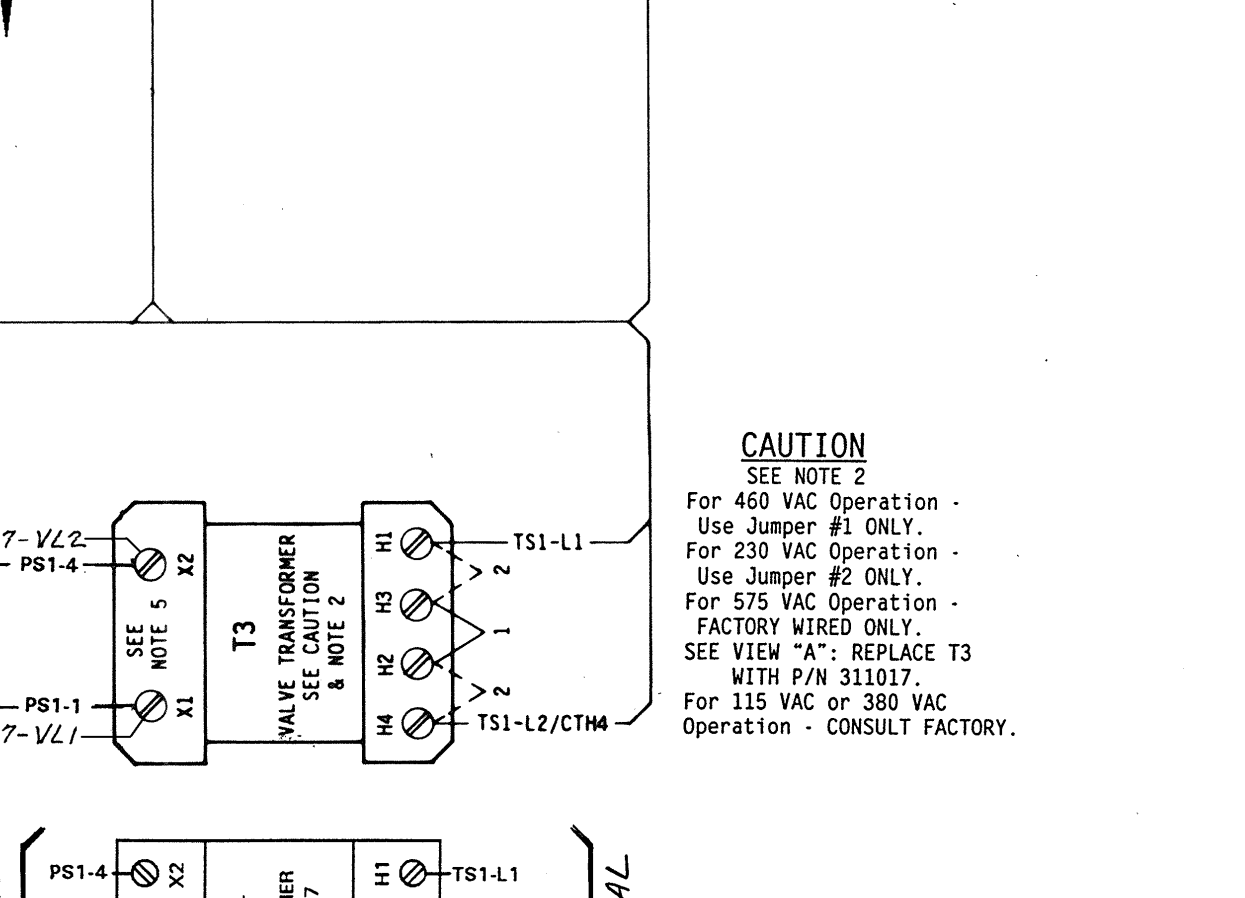
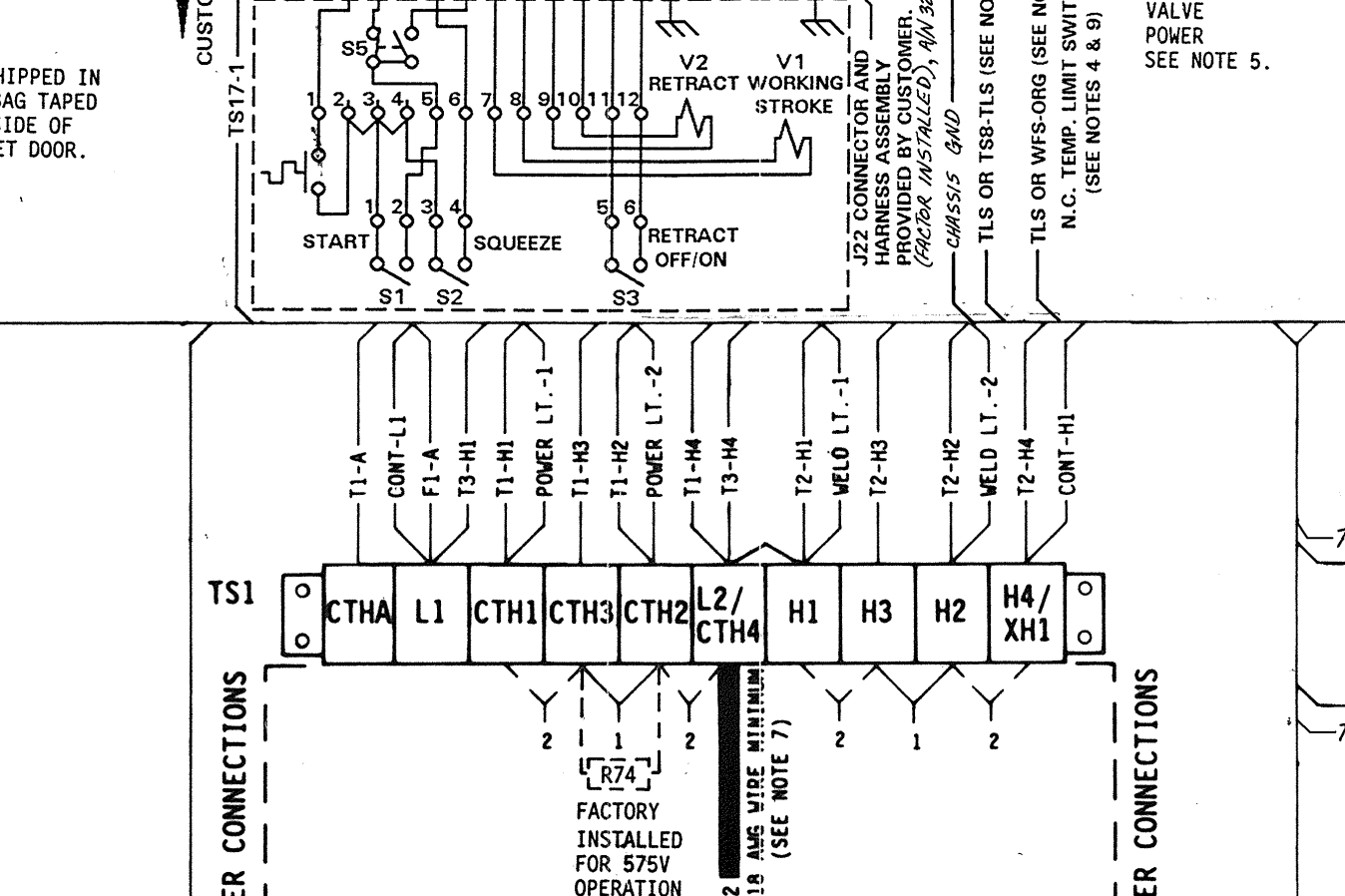
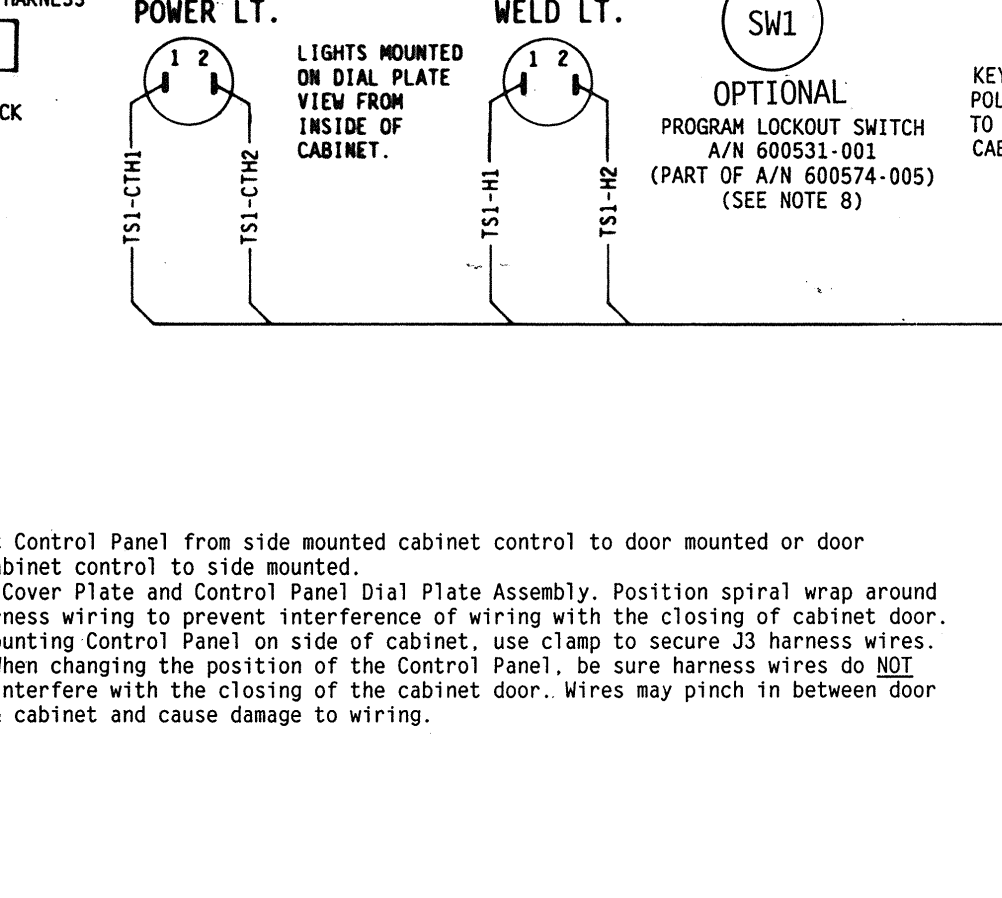
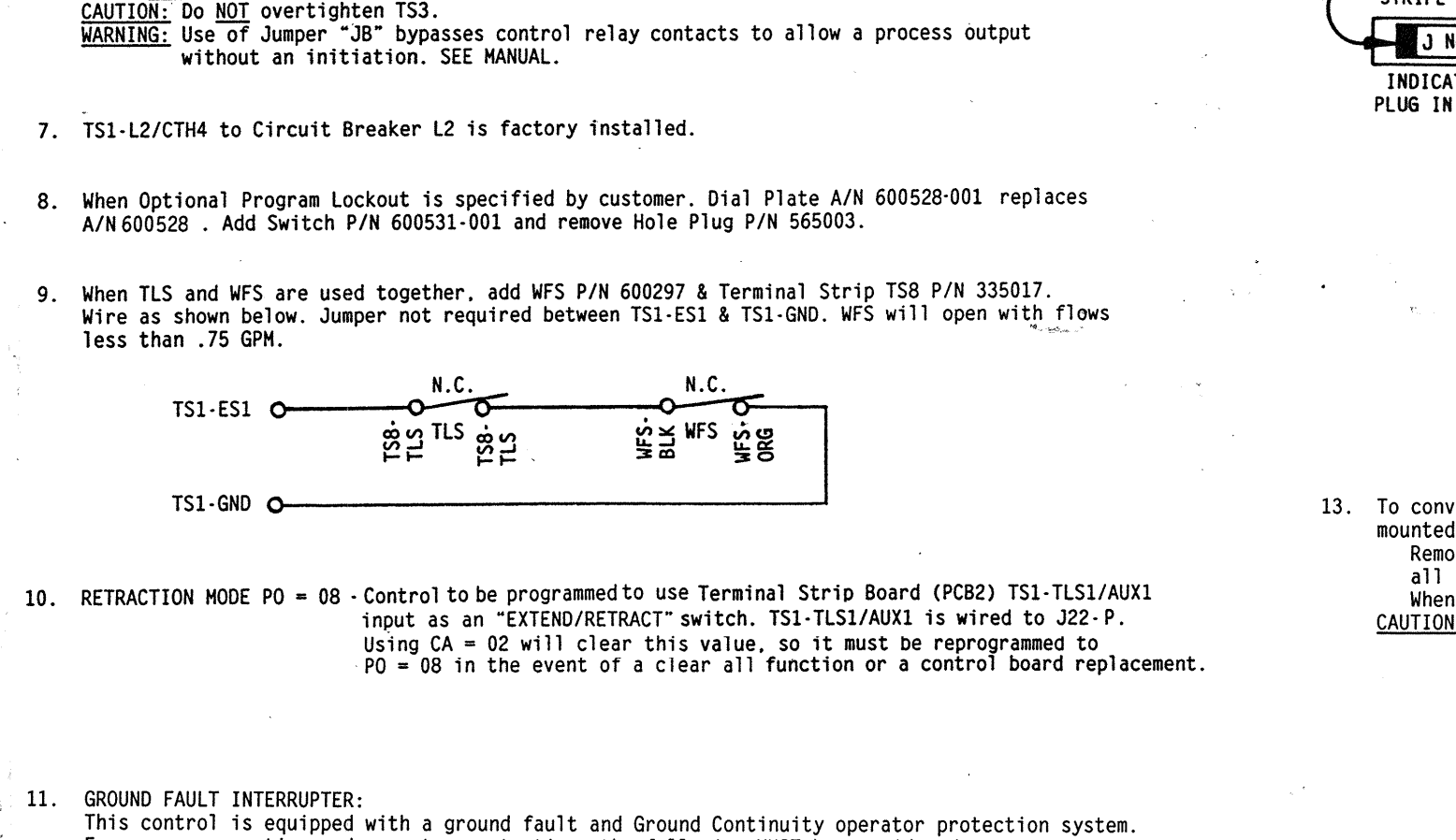

MANUFACTURING INSTRUCTIONS: * Substitution or addition of parts when 575V control is specified. * Optional Keylock when specified by customer. See Note 8. * Pack Key in Poly Bag 900148 & attach to Door w/Yellow Tape 900118.

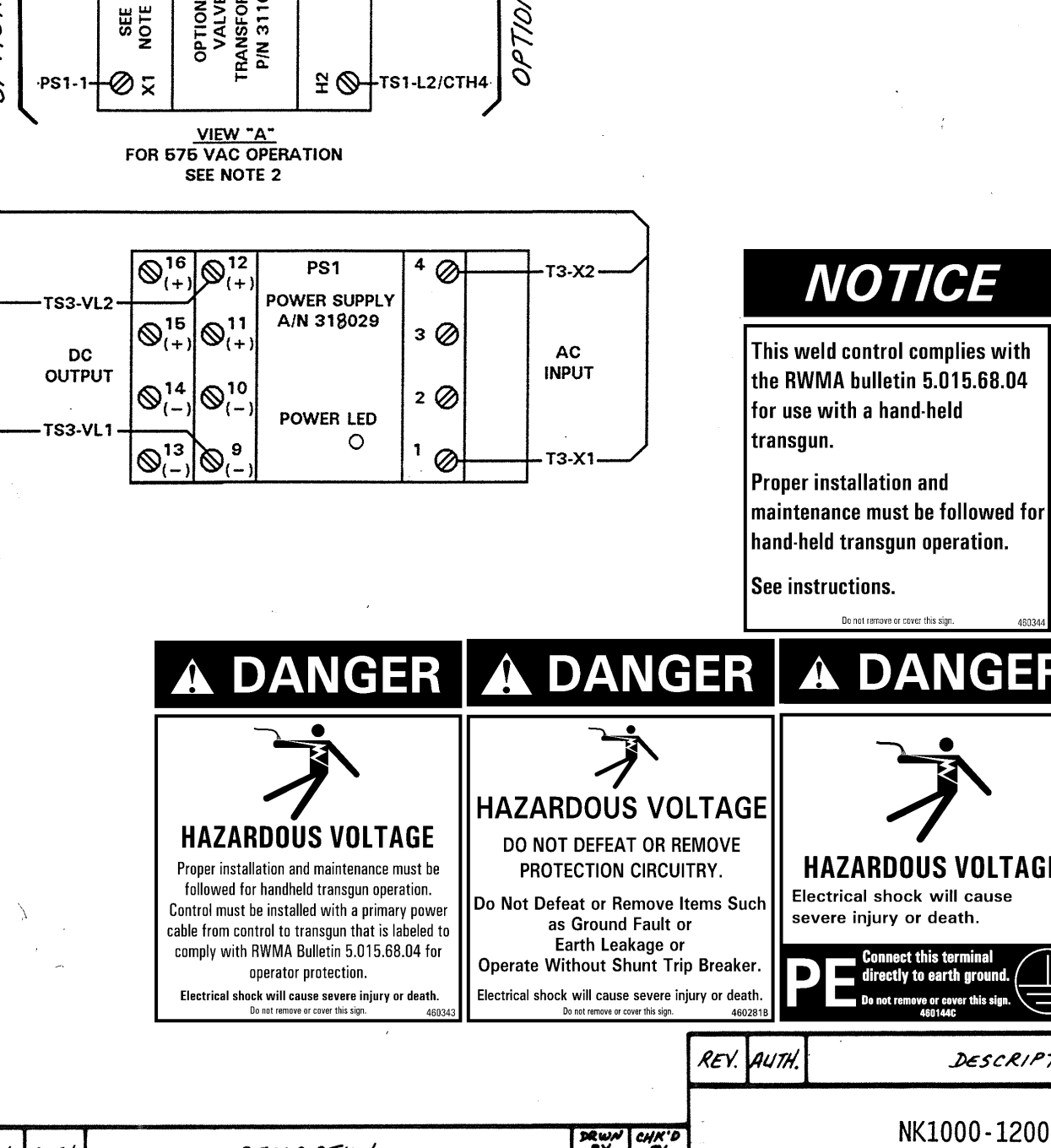
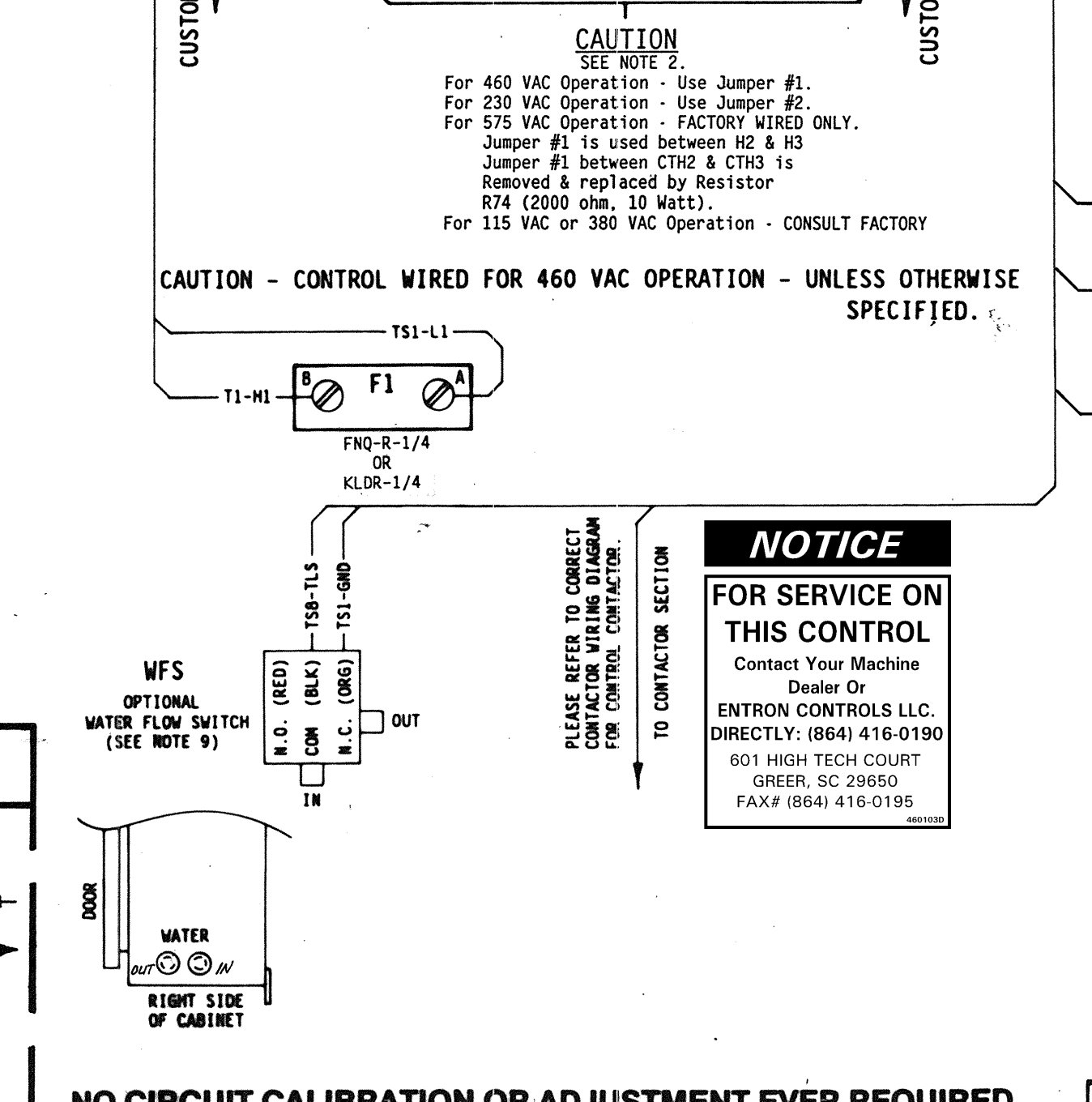
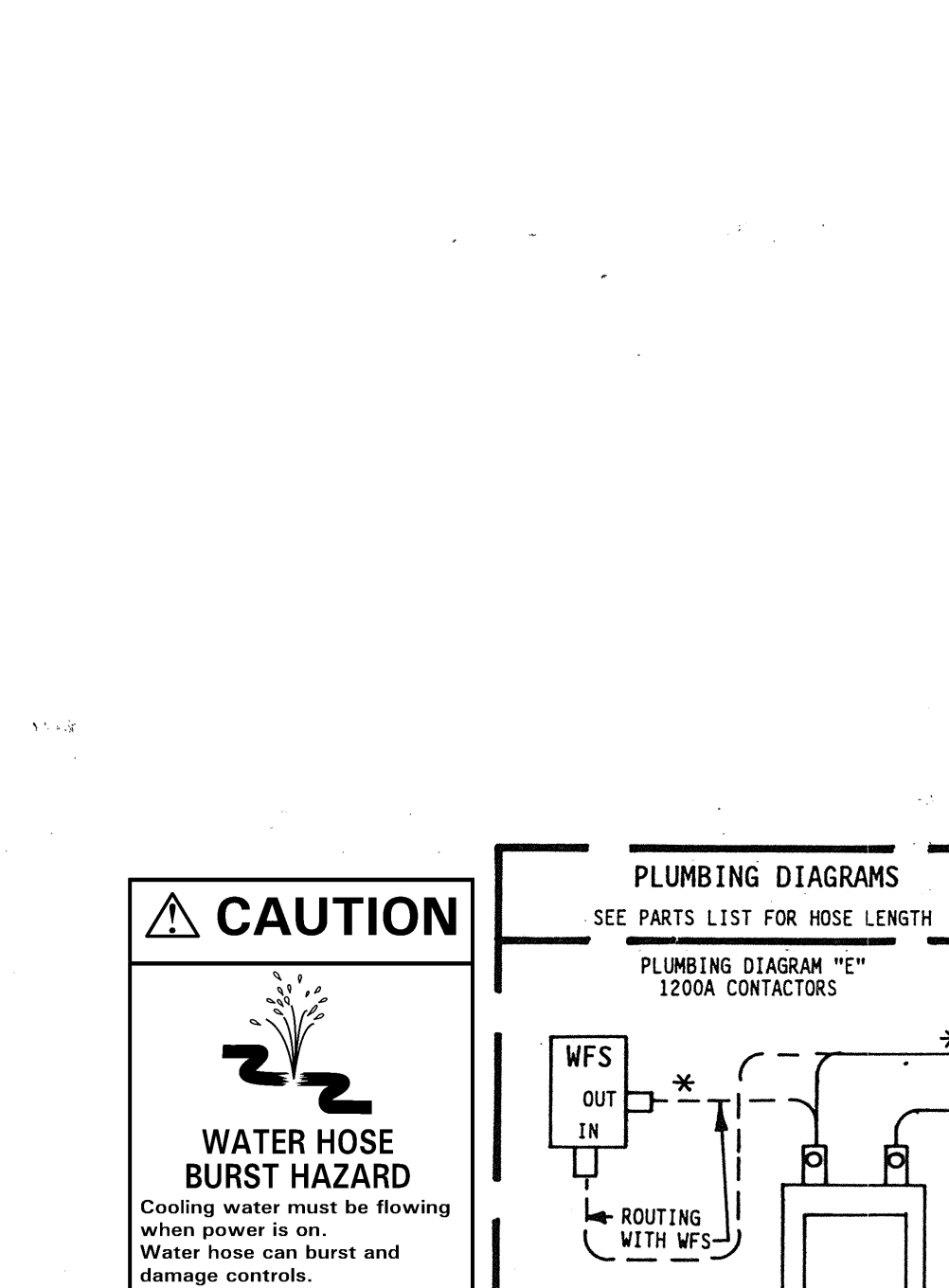
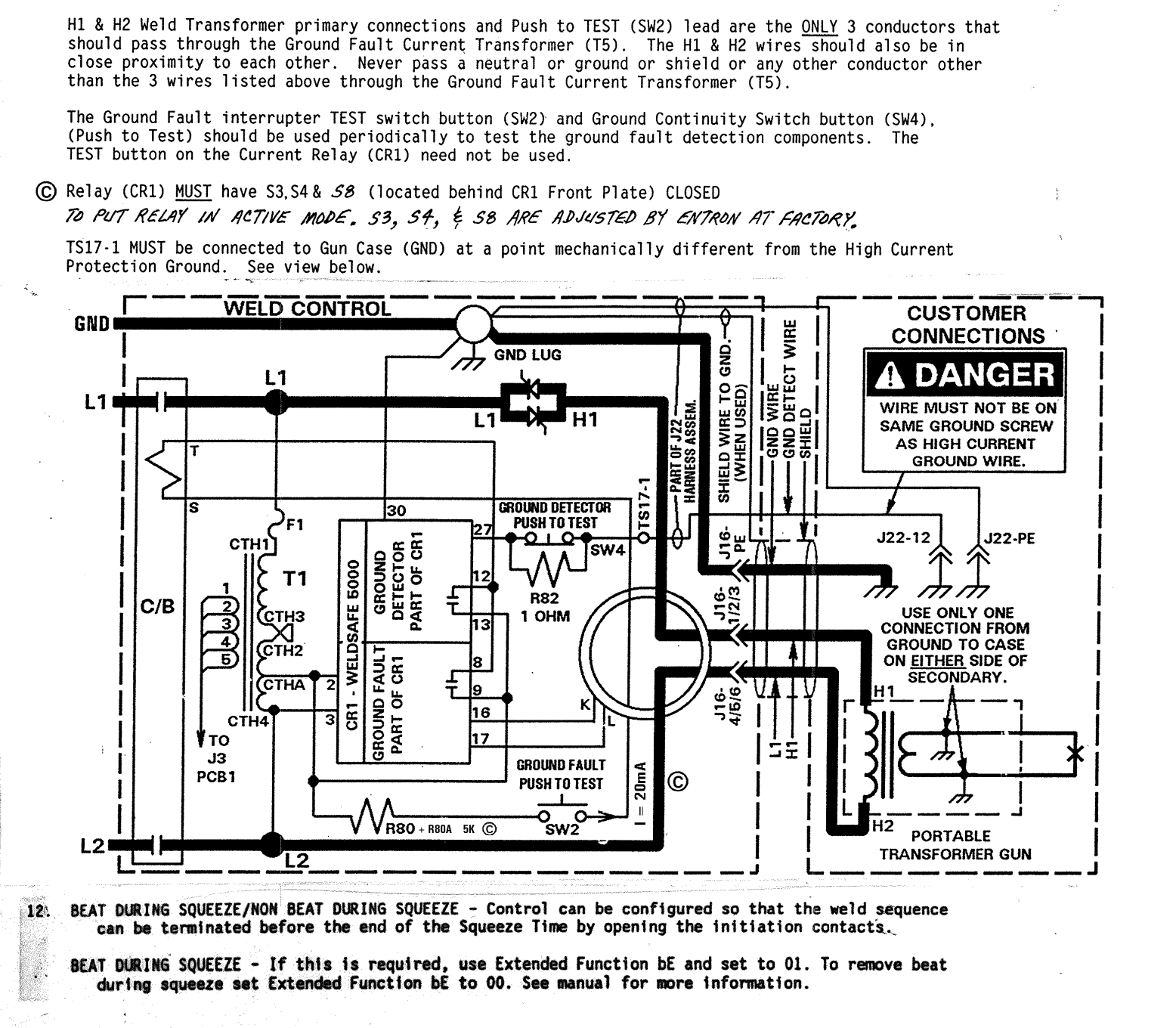

NOTICE: This weld control complies with the RWMA bulletin 5.015.68.04 for use with a hand-held transgun. Includes a table with columns: REV. AUTH., DESCRIPTION, DATE, and a revision history table.