

CAUTION - READ MANUAL & ALL NOTES BEFORE INSTALLING OR OPERATING CONTROL. SEE NOTE 1.

▲ DANGER

HAZARDOUS VOLTAGE FROM ONE OR MORE SOURCES Turn off all voltage sources before touching any components. Electrical shock or flash will cause severe injury or death. Do not remove or cover this tag.

421387 F

Table with columns: QTY., DESIG., PART NO., DESCRIPTION. Lists parts for EN1000-600D, T and EN1000-1200D, T.

Table with columns: QTY., DESIG., PART NO., DESCRIPTION. Lists parts for EN1000-600D, T and EN1000-1200D, T.

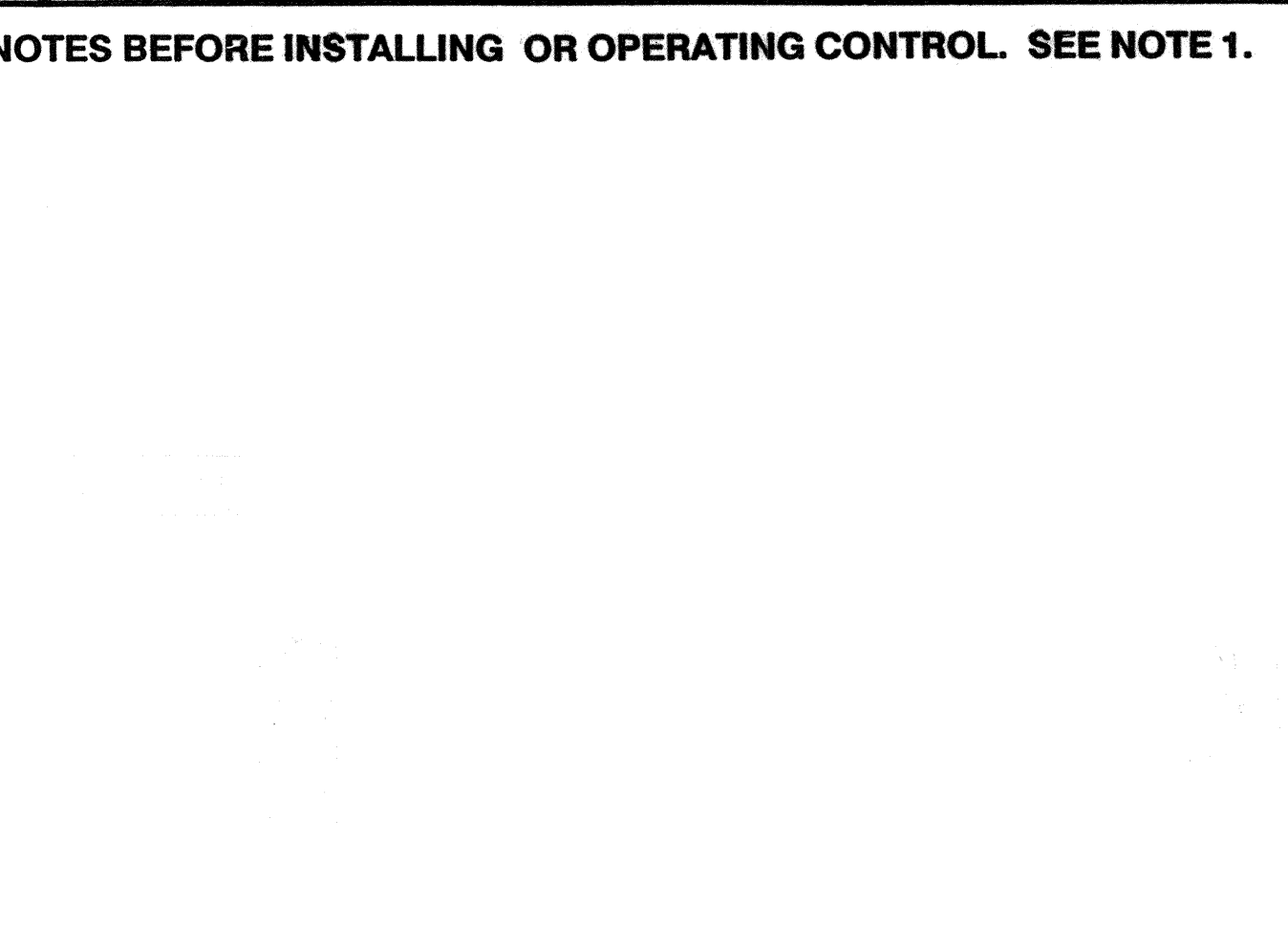
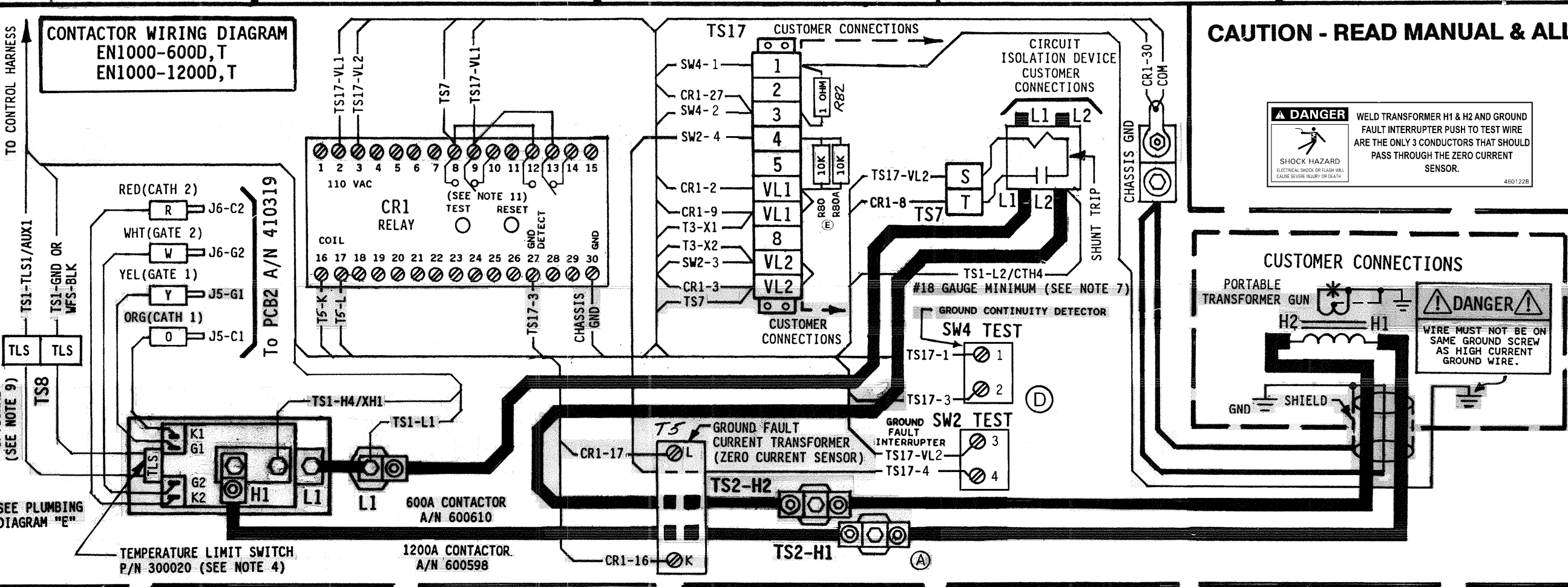

CAUTION Control Shipped Wired for 460 VAC Unless otherwise specified - See Note 2.

- NOTES: 1. It is recommended that control wiring... 2. For 460 VAC Operation - Use Jumper #1... 3. For Single Stage Pilot Operation...

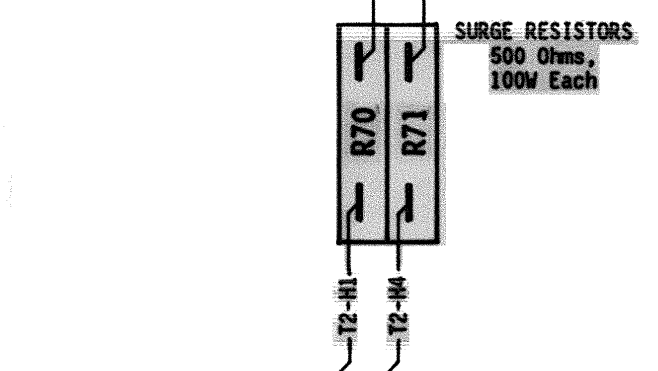
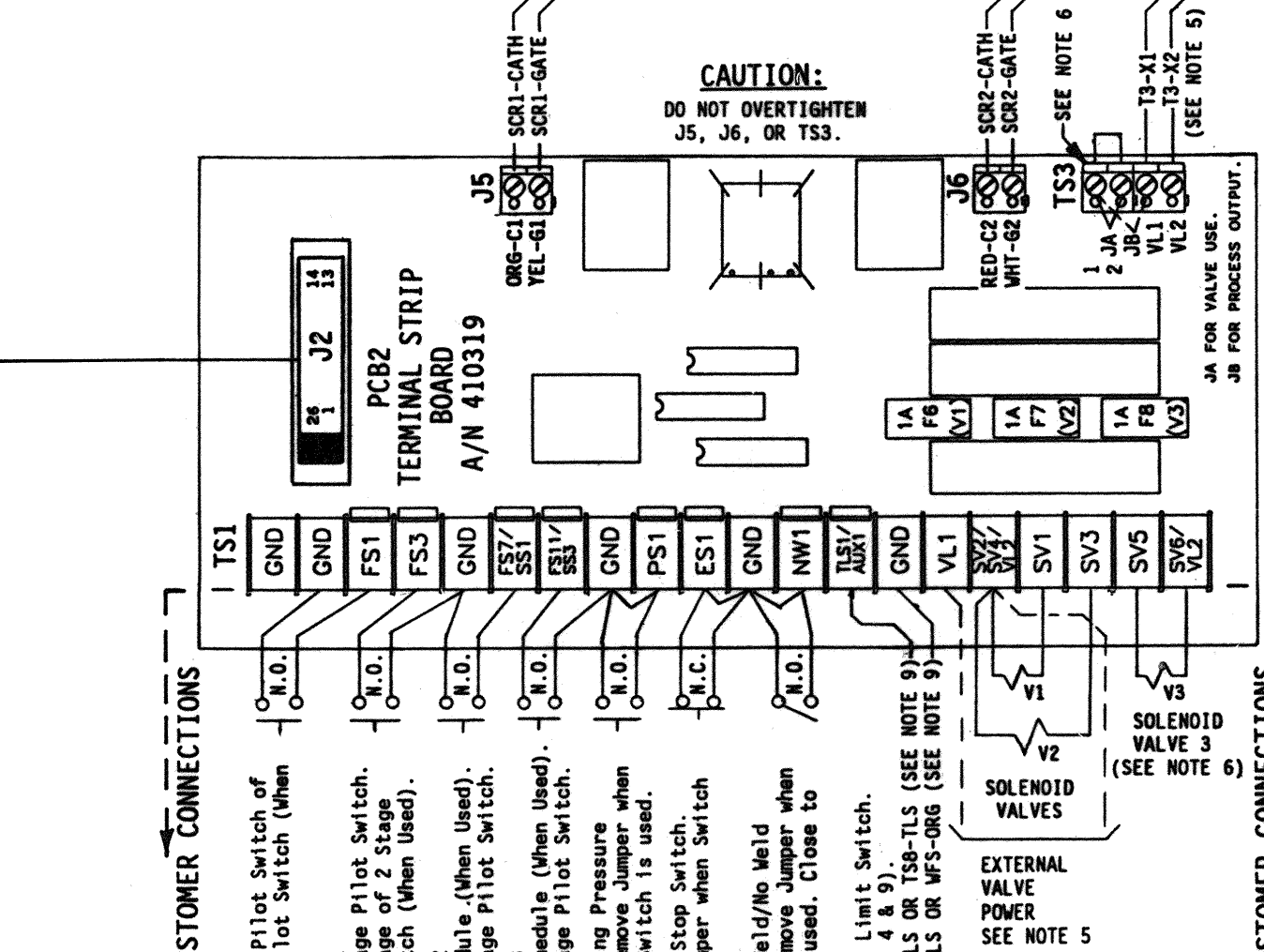
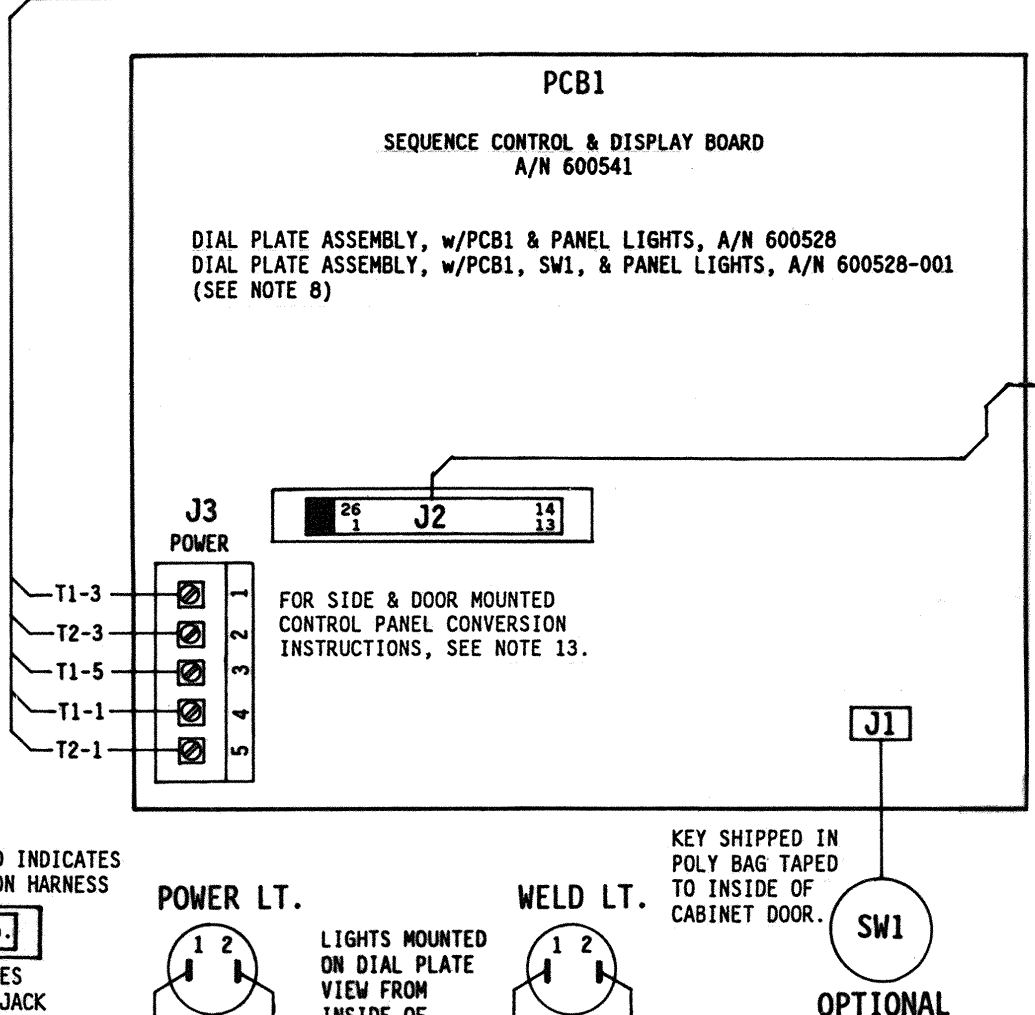

- NOTES: 4. EN1000-600/1200, "D/T" CABINET: ENTIRON supplies Temperature Limit Switch... 5. When external valve power is supplied to the control...

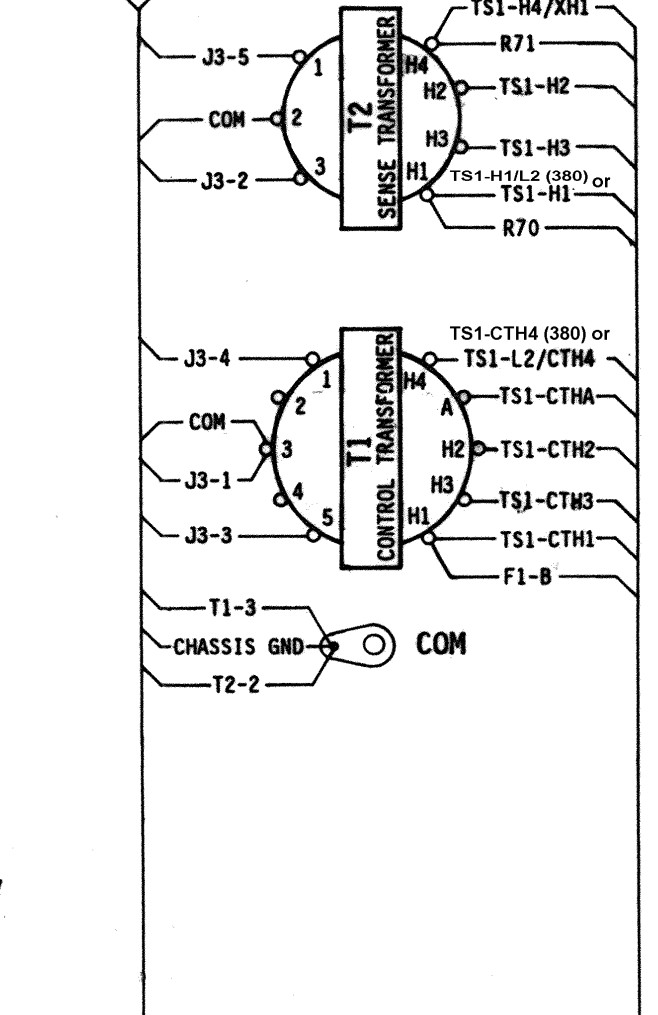
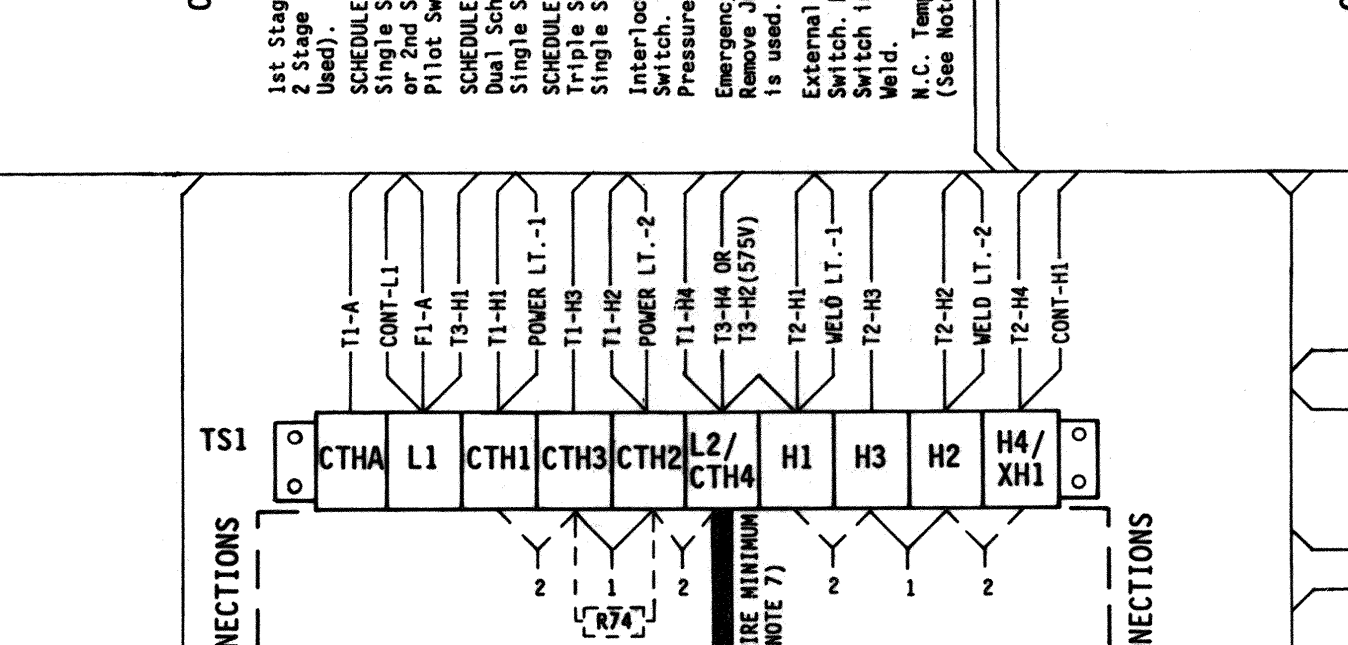
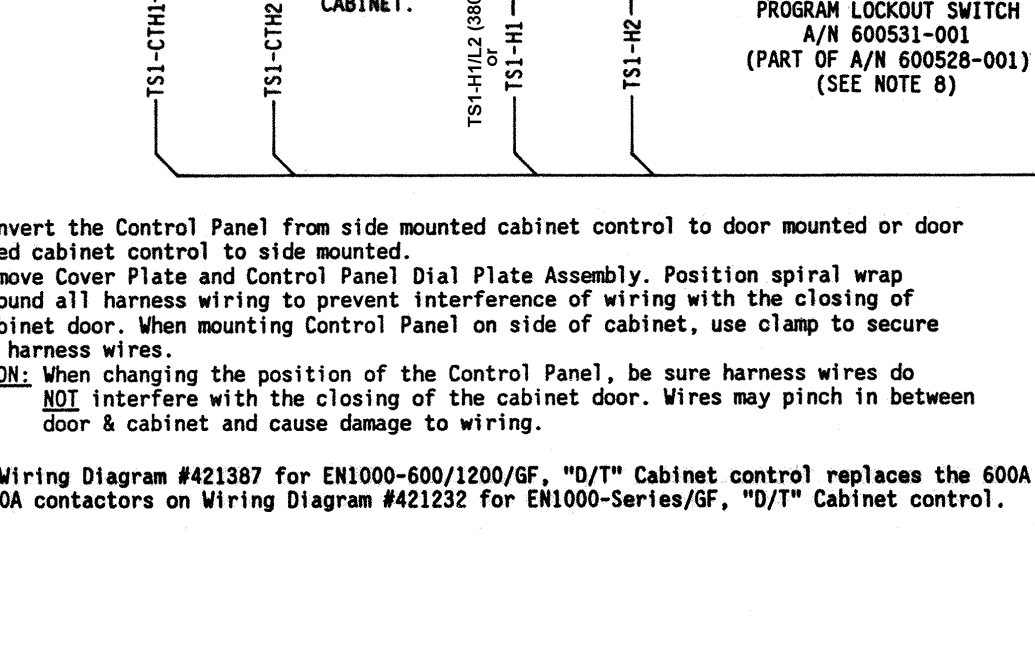

- NOTES: 6. Valve Usage: When using this control with air over all Portable Transformer Guns... 7. TSI-L2/CTH4 without Circuit Breaker L2 is Factory Installed.

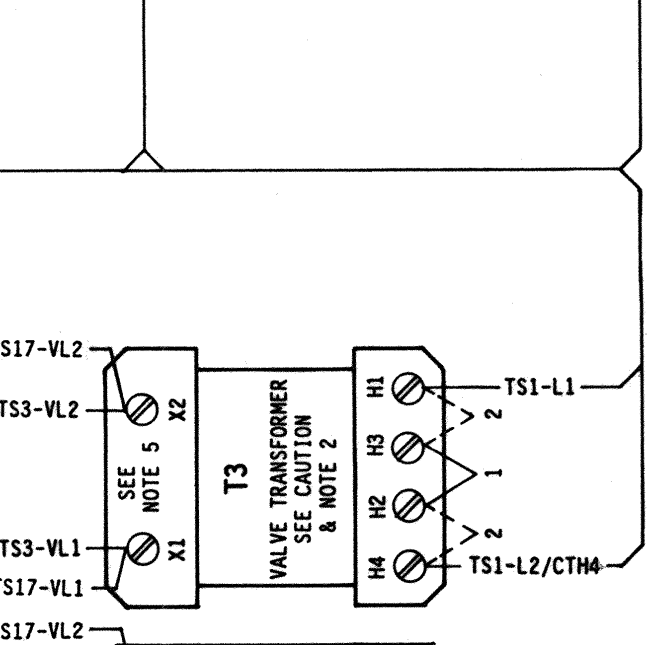
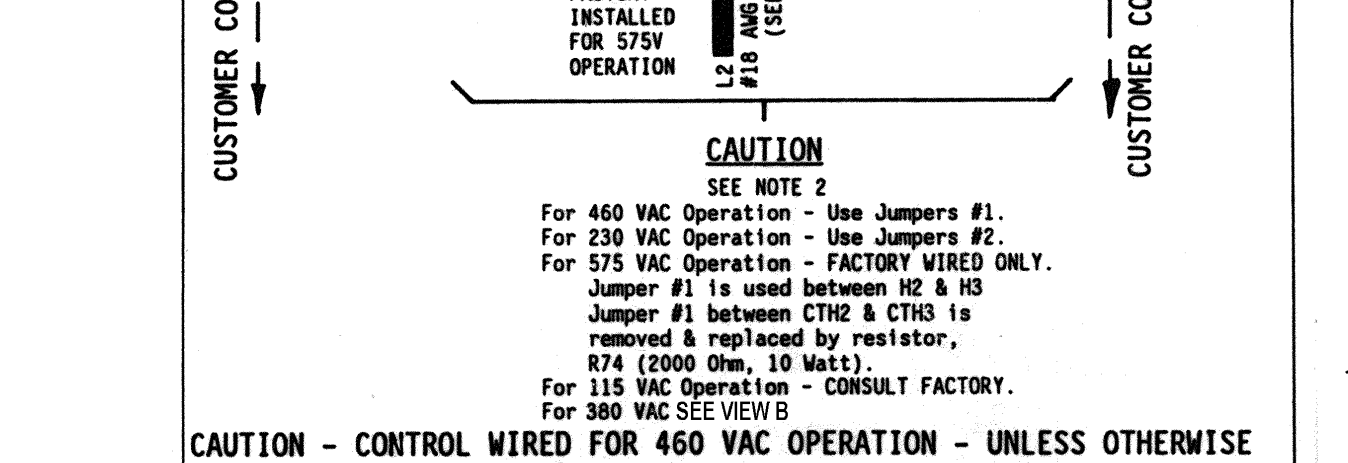
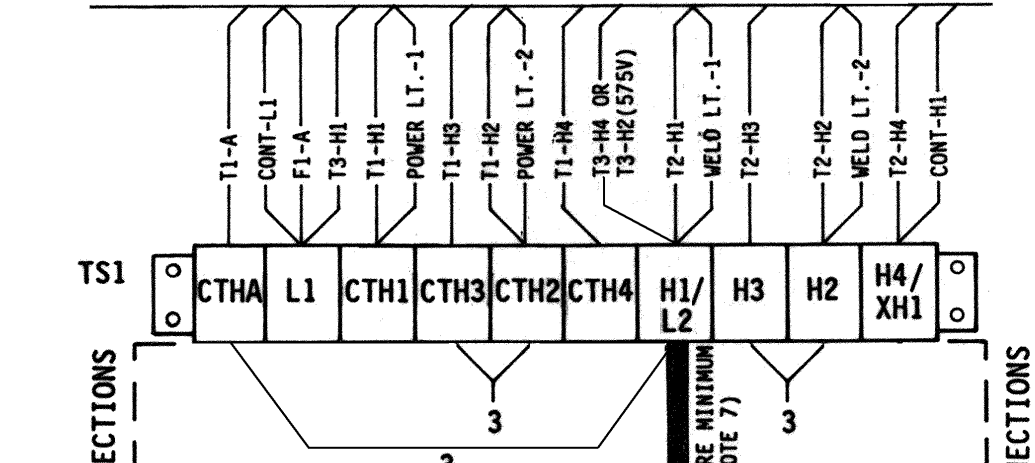

CAUTION SEE NOTE 2 For 460 VAC Operation - Use Jumper #1 ONLY. For 230 VAC Operation - Use Jumper #2 ONLY. For 575 VAC Operation - Use Jumper #3 ONLY.

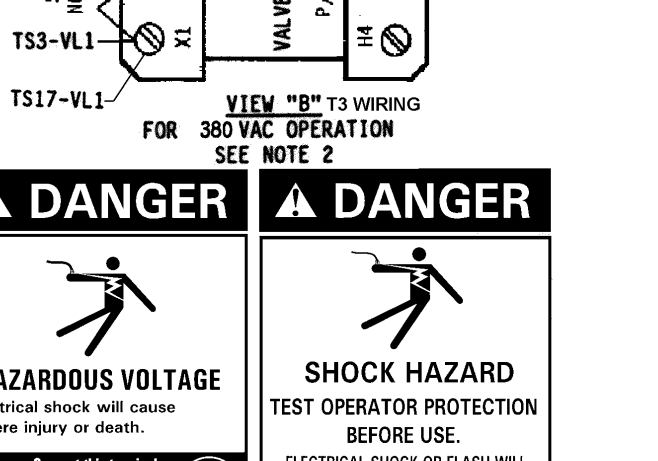
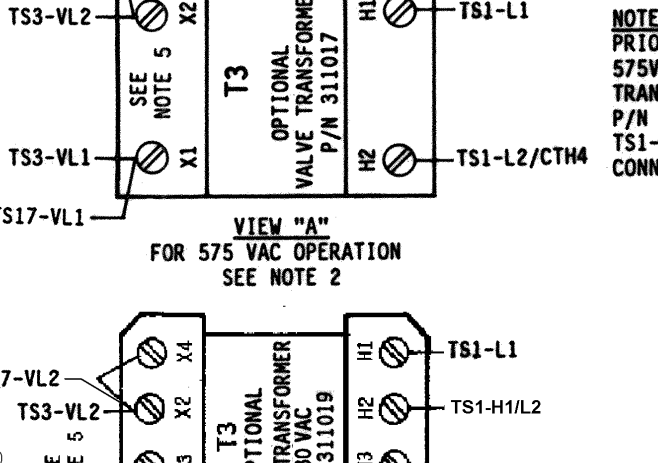
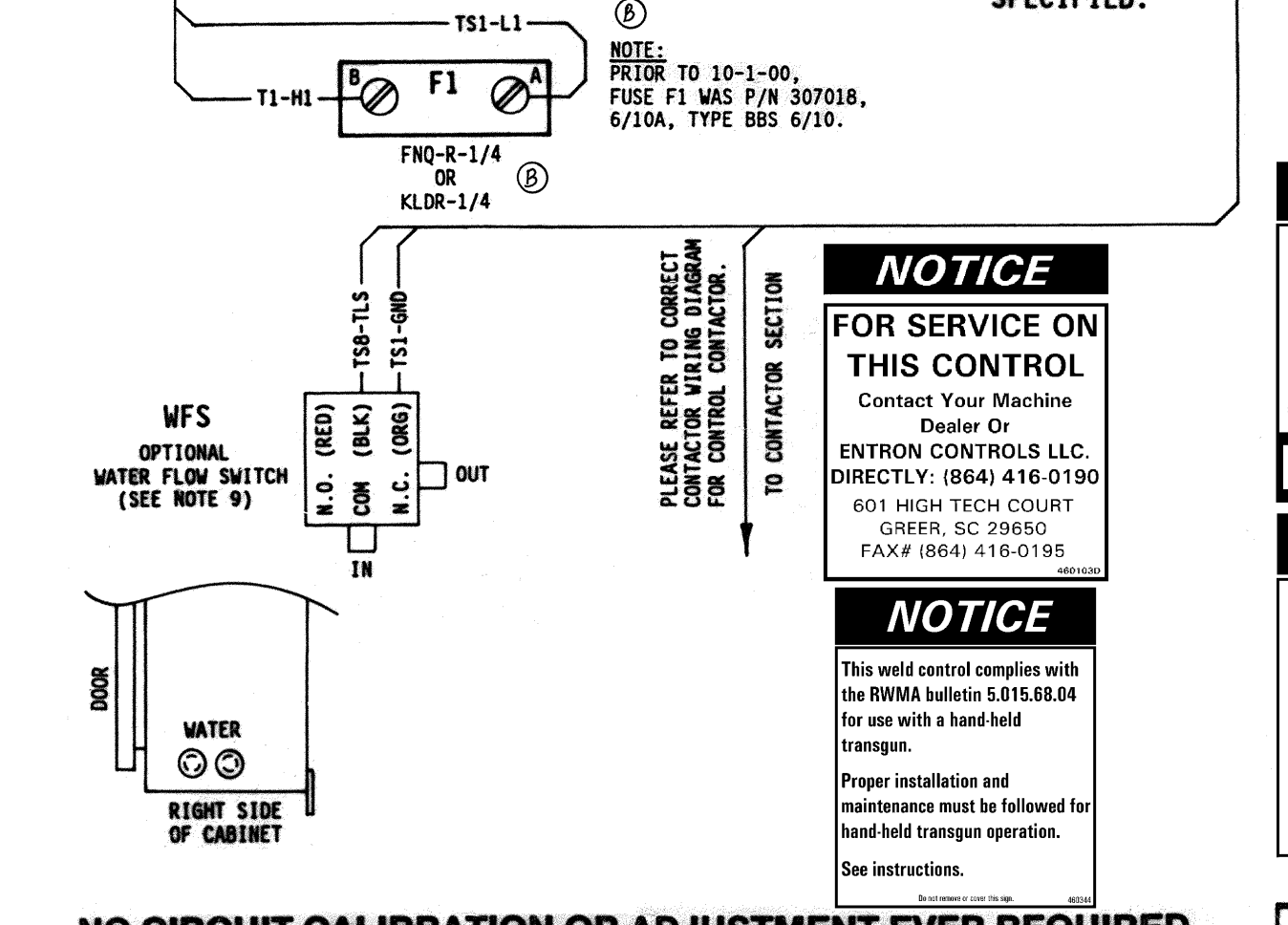
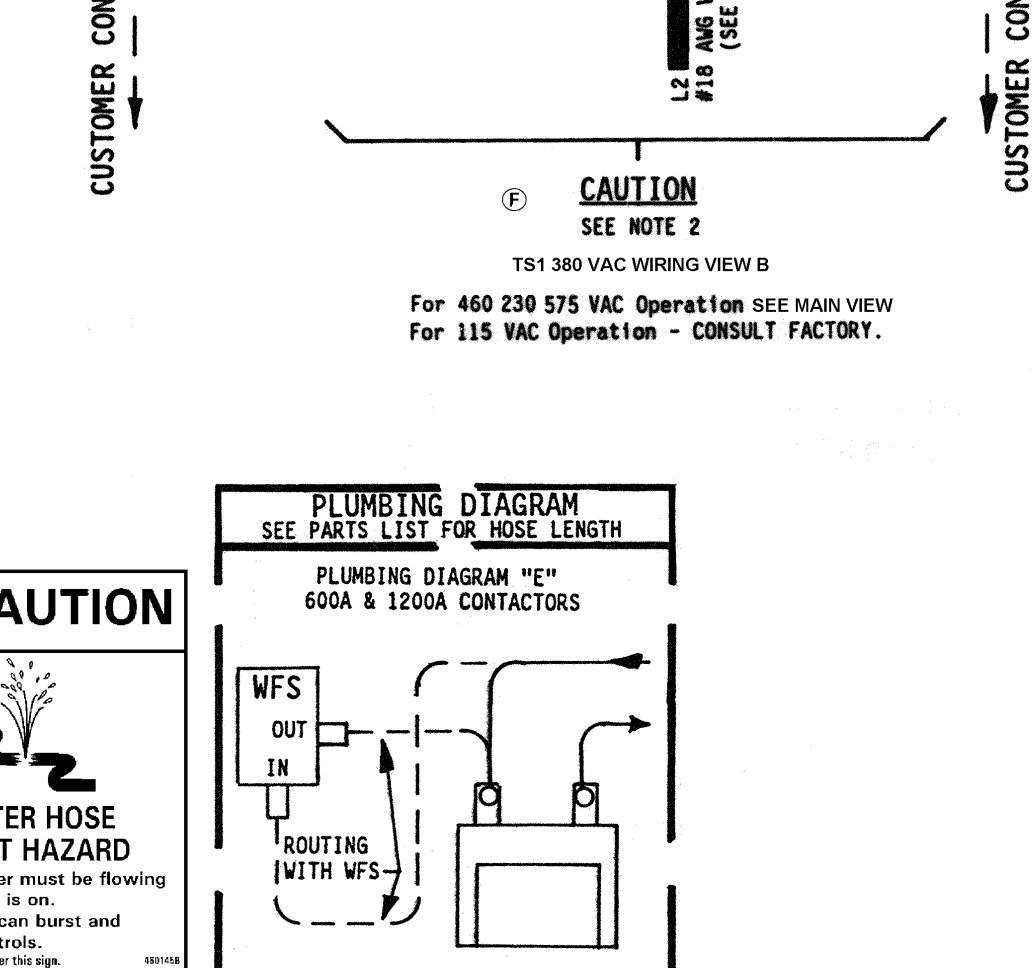
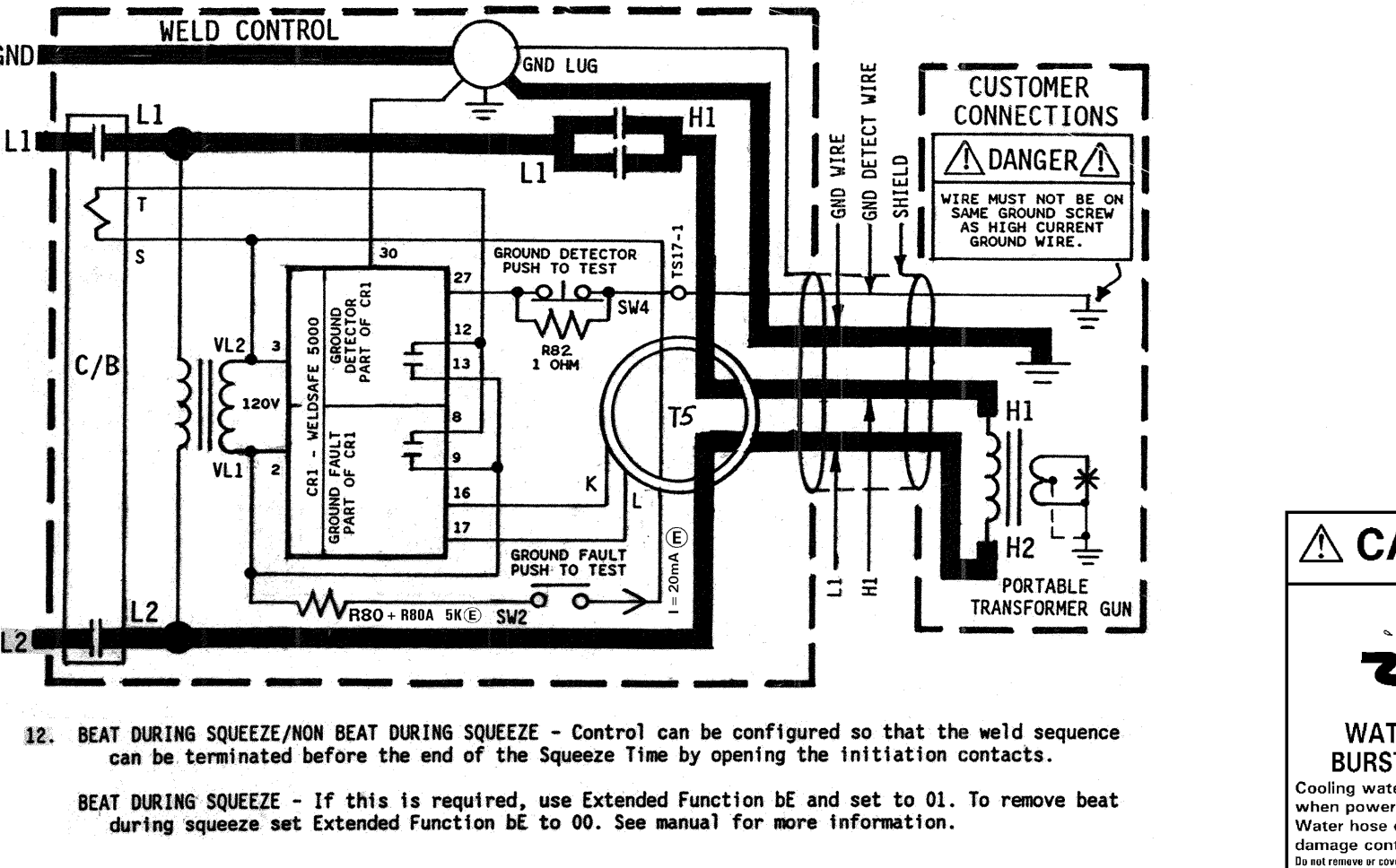

▲ DANGER HAZARDOUS VOLTAGE Electrical shock will cause severe injury or death.

▲ DANGER SHOCK HAZARD TEST OPERATOR PROTECTION BEFORE USE. ELECTRICAL SHOCK OR FLASH WILL CAUSE SEVERE INJURY OR DEATH.

▲ DANGER HAZARDOUS VOLTAGE Do NOT DEFER OR REMOVE PROTECTION CIRCUITRY. Do Not Defeat or Remove Items such as Ground Fault or Earth Leakage or Operate Without Shunt Trip Breaker.

- NOTES: 12. BEAT DURING SQUEEZE/NON BEAT DURING SQUEEZE - Control can be configured so that the weld sequence can be terminated before the end of the Squeeze Time...

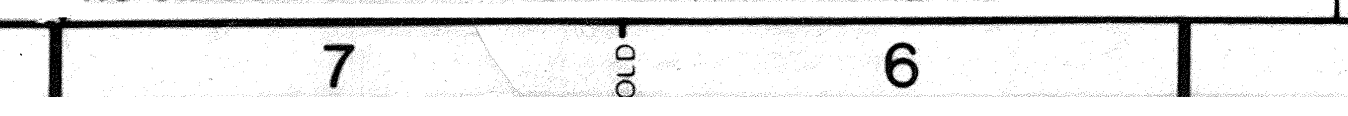
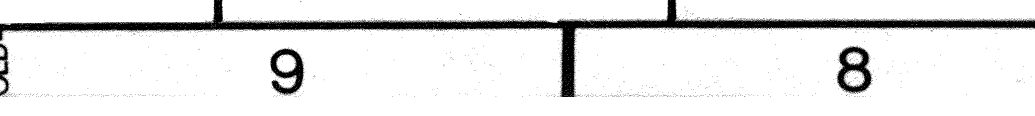

HAZARDOUS VOLTAGE Do NOT DEFER OR REMOVE PROTECTION CIRCUITRY. Do Not Defeat or Remove Items such as Ground Fault or Earth Leakage or Operate Without Shunt Trip Breaker.

Table with columns: REV, AUTH, DESCRIPTION, DATE. Lists revisions to the drawing.

ENTIRON CONTROLS INC. WIRING DIAGRAM, EN1000-600 or 1200 /GF, "D/T" CABINET, WITH CIRCUIT BREAKER 120 VAC VALVES, WIRED FOR 240 OR 380 OR 575 VAC.

421387-F